

Operating Instructions

B 500

Automatic Grinding and Polishing Machine



Operating Instructions

Automatic Grinding and Polishing Machine B 500

Manufacturer

KNECHT Maschinenbau GmbH
Witschwender Straße 26
88368 Bergatreute
Germany

Phone +49-7527-928-0
Fax +49-7527-928-32

mail@knecht.eu
www.knecht.eu

Documents for the machine operator

Operating Instructions

Date of issue of the operating instructions

November 3, 2023

Copyright

The copyright for these operating instructions as well as other documents for the machine operator is held by KNECHT Maschinenbau GmbH. These documents will be delivered only to our customers and to operators of our products and are a part of the machine.

These documents may neither be reproduced, nor made accessible to third parties, including rival firms, without our express permission.

Table of Contents

1.	Important notes	7
1.1	Foreword	7
1.2	Warnings and symbols in the operating instructions	7
1.3	Warning and mandatory signs and their meaning	8
1.3.1	Warning and mandatory signs on/in the grinding machine	8
1.4	Rating plate and machine serial number	9
1.5	Figure and item numbers in the operating instructions	10
2.	Safety	11
2.1	Basic safety instructions	11
2.1.1	Observe notes in the operating instructions	11
2.1.2	Operator's duty	11
2.1.3	Obligations on the part of the personnel	11
2.1.4	Hazards associated with handling the machine	11
2.1.5	Malfunctions	12
2.2	Use as intended	12
2.3	Warranty and Liability	12
2.4	Safety regulations	13
2.4.1	Organizational measures	13
2.4.2	Protective devices	13
2.4.3	Informal safety measures	13
2.4.4	Selection and qualifications of the personnel	14
2.4.5	Machine control system	14
2.4.6	Safety measures in normal operation	14
2.4.7	Hazards due to electrical power sources	14
2.4.8	Particular danger zones	15
2.4.9	Servicing (maintenance, repair) and fault rectification	15
2.4.10	Structural alterations to the grinding machine	15
2.4.11	Cleaning the grinding machine	15
2.4.12	Lubricants/oils and greases	16
2.4.13	Relocation of the grinding machine	16
3.	Description	17
3.1	Intended Use	17
3.2	Technical specifications	17
3.3	Functional description	18
3.4	Description of the assemblies	19
3.4.1	Switching the grinding machine on/off	21
3.4.2	Control panel	21
3.4.3	Structure of the user interface (main screen)	22
3.4.4	Coolant Pump	24
3.4.5	Protective Hood	25
3.4.6	SP 112 Copy grinding plate	25
3.4.7	Grinding Unit	25
3.4.8	Polishing units with polishing paste	26

Table of Contents

4.	Transport	27
4.1	Transport Aids	27
4.2	Transport damage	27
4.3	Transport to another installation site	27
5.	Installation	29
5.1	Selection of qualified personnel	29
5.2	Installation site	29
5.3	Supply connections	29
5.4	Settings	29
5.5	Initial commissioning of the grinding machine	30
6.	Commissioning	31
7.	Operation	33
7.1	General principles of grinding technology	33
7.2	Changing the profile	34
7.3	Grinding the cutter knives	35
7.3.1	Switching on the grinding machine	35
7.3.2	Mounting the copy grinding plate	35
7.3.3	Adjusting the grinding angle	37
7.3.4	Aligning the grinding unit	37
7.3.5	Aligning the deburring unit	39
7.3.6	Aligning the polishing unit	40
7.3.7	Starting the grinding process	40
7.4	Changing the copy grinding plate	41
7.5	Changing the wet grinding belt	43
7.6	Changing the finned brush of the polishing unit	44
7.7	Changing the finned brushes of the deburring unit	45
7.8	Changing the polishing pastes	46
8.	Control system	47
8.1	Main Screen	47
8.2	Activating the product file	48
8.3	Renaming, creating and deleting the product file	49
8.3.1	Renaming product file	49
8.3.2	Creating the product file	50
8.3.3	Deleting the product file	50

Table of Contents

8.4	Editing the parameters of the product file	51
8.4.1	Meaning of "Grinding" parameters	52
8.4.2	Meaning of "Feed Cycles" parameter	54
8.4.3	Meaning of "Polishing Process" parameters	56
8.5	Settings Data	58
8.6	Manual Functions	60
8.7	Language	61
8.8	Setting up an internet connection	62
9.	Care and maintenance	63
<hr/>		
9.1	Lubrication and Maintenance	63
9.1.1	Lubrication schedule and lubricant table	64
9.2	Cleaning	65
9.2.1	Cleaning of sub-structure	66
9.3	Maintenance plan	67
10.	Disassembly and disposal	68
<hr/>		
10.1	Disassembly	68
10.2	Disposal	68
11.	Service, spare parts and accessories	69
<hr/>		
11.1	Postal Address	69
11.2	Service	69
11.3	Wear and spare parts	69
11.4	Accessories	70
11.4.1	Abrasives used	70
12.	Appendix	71
<hr/>		
12.1	EU Declaration of Conformity	71

1. Important notes

1.1 Foreword

These operating instructions are meant to make it easier to get to know the automatic grinding and polishing machine, referred to in this document as grinding machine, and to use it properly for the intended purpose.

The operating instructions contain important information on how to operate the grinding machine safely, properly and cost-effectively. Observance of these instructions helps to avoid dangers, repair costs and downtimes, and increases the reliability and service life of the grinding machine.

The operating instructions must always be accessible at the place of use of the grinding machine.

The operating instructions must be read and used by all persons entrusted with working on the grinding machine, e.g. those entrusted with

- Transport, installation, commissioning
- Operation, including troubleshooting in the process flow, as well as
- Servicing (maintenance, repair).

In addition to the operating instructions and the binding accident prevention regulations applicable in the country and place of use of the machine, the generally acknowledged rules of technology with regard to safe and professional work practices are to be observed.

1.2 Warnings and symbols in the operating instructions

Heeding the following safety alert symbols/designations used in the operating instructions is absolutely necessary:



The hazard triangle with the signal word "CAUTION" is used as a work safety indication for all work which could result in death or physical injury.

Special care and caution must be taken when carrying out such jobs.



"ATTENTION" is written in places where special attention must be paid to prevent damage or destruction of the grinding machine or its surroundings.



The signal word "NOTE" calls attention to tips on use and useful information.

1. Important notes

1.3 Warning and mandatory signs and their meaning

1.3.1 Warning and mandatory signs on/in the grinding machine

The following warnings and safety alert signs have been affixed to the grinding machine:



CAUTION! DANGEROUS ELECTRICAL VOLTAGE (warning notice on the switch cabinet)

The grinding machine carries life-threatening voltage when it is connected to the power supply.

Voltage-carrying device parts may only be opened by authorized personnel.

The grinding machine must be separated from the mains supply before carrying out servicing, maintenance and repair work on it.



CAUTION! RISK OF INJURY FROM KNIFE (warning notice on the polishing unit)

Work on the grinding machine involves the sharpening of knives which could cause serious cut injuries due to their sharpness.

Protective gloves must be worn when clamping and releasing knives.

Caution when transporting knives. Use the protective equipment provided by the knife manufacturer. Protective gloves and safety shoes must be worn.

1. Important notes

1.4 Rating plate and machine serial number

KNECHT		Maschinenbau GmbH Witschwender Strasse 26 88368 Bergatreute Germany 07527-928-0 www.knecht.eu	
Automatische Schleif- u. Poliermaschine			
TYPE	B 500	Bauj.	2016
Masch.-Nr.	820463500		
V	400	A	25 Gew. 900 kg
KW	8,0	Hz	50 Sch. Y
Motor	Schleifbandantrieb		
V	400	n1	1400/min n2
KW	2,2	A	2,5 Hz 50 Sch Y
Motor	Polierantrieb rechts		
V	400	n1	2870/min n2
KW	1,1	A	2,5 Hz 50 Sch Y
Motor	Polierantrieb links		
V	400	n1	1360/min n2
KW	0,7	A	2 Hz 50 Sch Y

The rating plate (1-1) is located on the left side of the machine.

Figure 1-1 Rating plate



The machine number (1-2) is located on the rating plate (1-1) and on the top right of the machine.

Figure 1-2 Machine serial number

1. Important notes

1.5 Figure and item numbers in the operating instructions

If the text refers to a machine component shown in a figure, then a figure or item number is added in brackets after the machine component.

Example: (7-5/1) denotes figure number 7-5, item 1.

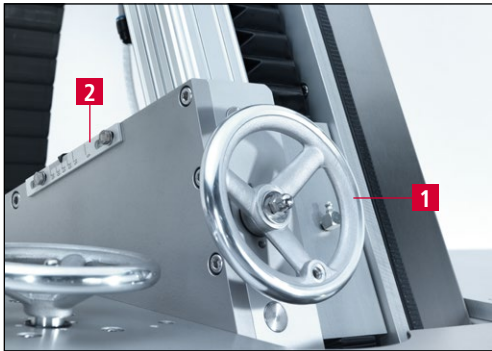

Adjusting the grinding angle with the hand wheel (7-5/1).

The grinding angle can be read off the scale (7-5/2).

Figure 7-5 *Adjusting the grinding angle*

2. Safety

2.1 Basic safety instructions

2.1.1 Observe notes in the operating instructions

The basic prerequisite for safe handling and uninterrupted operation of this grinding machine is knowledge of the basic safety instructions and regulations.

- These operating instructions contain important notes on how to operate the grinding machine safely.
- All persons carrying out work on the grinding machine must follow these operating instructions, in particular the safety notices.
- In addition, the accident prevention rules and regulations applicable at the place of use of the machine must also be observed.

2.1.2 Operator's duty

The operator is obliged to allow only those persons to work on the grinding machine, who

- are familiar with the basic occupational safety and accident prevention regulations and have been trained and instructed in the handling of the grinding machine,
- have read and understood the operating instructions, in particular the section entitled "Safety" and the warning notes, and have provided signed confirmation of this.

Checks are also carried out at regular intervals to ensure that the worker is fulfilling his employee obligation to observe safety at work.

2.1.3 Obligations on the part of the personnel

All the personnel working on the grinding machine shall be obliged to

- observe the basic occupational safety and accident prevention regulations,
- read the operating instructions, particularly the "Safety" chapter, and the warning notes. They must provide signed confirmation of this in writing.

2.1.4 Hazards associated with handling the machine

The grinding machine has been built to the latest technological standards and the acknowledged rules of technical safety. In spite of that, its use presents inherent risks which could result in bodily harm or even death of the user or third persons, or impairment of the grinding machine or other property.

2. Safety

The grinding machine may only be used:

- for the intended purpose, and
- in faultless condition with regard to safety-relevant aspects.

Faults that could impair safety must be eliminated immediately.

2.1.5 Malfunctions

If safety-relevant malfunctions occur in the grinding machine, or if the processing behavior indicates that such malfunctions may have occurred, the grinding machine must be stopped immediately until such time as the malfunction has been found and eliminated.

The malfunctions must be eliminated by authorized technical staff.

2.2 Use as intended

The grinding machine is only meant for the automatic grinding, deburring and polishing of flat machine cutting knives.

Before starting work on a flat knife, it must be checked whether the knife fits on the knife holder.

Any other use is considered improper use. KNECHT Maschinenbau GmbH assumes no liability for damages resulting from improper use. The user alone bears the risk in such cases.

Use as intended includes the observance of all the instructions in the operating instructions.

ATTENTION

Improper use of the grinding machine exists, for example, if:

- **devices are not fastened properly.**
- **work pieces other than flat machine cutting knives are ground.**

2.3 Warranty and Liability

Warranty and liability claims in case of personal injuries or property damage are excluded if such damage is attributable to one or more of the following causes:

- improper use of the grinding machine,
- improper transportation, commissioning, operation and maintenance of the grinding machine,
- operating the grinding machine with defective safety devices, or improperly attached or malfunctioning safety and protective equipment,

2. Safety

- ignoring the operating instructions with regard to transportation, commissioning, operation, maintenance and repair of the grinding machine,
- unauthorized structural alterations to the grinding machine,
- unauthorized modification, e.g. of the drive conditions (power and speed), and
- insufficient monitoring of machine parts that are exposed to wear
- use of unapproved replacement and wear parts.

Use only original replacement and wear parts. If externally purchased parts are used, it is not guaranteed that they have been designed and manufactured to meet the requirements in terms of stress and safety.

2.4 Safety regulations

2.4.1 Organizational measures

All the existent safety devices must be checked regularly.

Observe prescribed intervals for recurring maintenance work or as specified in the operating instructions.

2.4.2 Protective devices

Before every commissioning of the grinding machine, ensure that all protective equipment is properly mounted and in functional condition.

Protective equipment may be removed only after the grinding machine has stopped and has been secured against accidental restart.

When attaching spare parts, the protective equipment must be attached by the operator as stipulated.

2.4.3 Informal safety measures

The operating instructions must be permanently available at the place of use of the grinding machine. In addition to the operating instructions, the generally applicable as well as locally relevant accident prevention regulations must also be made available and observed.

All safety alert symbols and hazard warnings on the grinding machine must be complete and clearly legible.

2. Safety

2.4.4 Selection and qualifications of the personnel

Only trained and instructed personnel may work on the grinding machine. The minimum legal age for employment must be observed.

The responsibilities of the personnel must be clearly assigned, i.e. commissioning, operation, maintenance and repair, etc.

Personnel still undergoing training or instruction may only work on the grinding machine under the permanent supervision of an experienced person!

2.4.5 Machine control system

Under no circumstances make program changes to the software. Parameters that the operator can set himself are excluded from this (e.g. setting the number of cycles).

Only trained and instructed personnel are permitted to switch on and operate the machine.

2.4.6 Safety measures in normal operation

Do not operate the machine in any unsafe manner. Only operate the grinding machine if all the safety devices are installed and fully functional.

At least once per shift (or per day), check the grinding machine for externally visible damage and proper functioning of the safety devices.

Immediately report any changes present (including those of the operating behavior) to the responsible office or person. If necessary, immediately shut down the grinding machine and secure it against restart.

Before you switch on the grinding machine, ensure that no one can be injured by the start-up of the machine.

In the event of a malfunction, immediately stop the grinding machine and secure it against restart. Rectify malfunctions immediately.

2.4.7 Hazards due to electrical power sources

The control cabinet must always be kept closed. Access is only permitted to authorized personnel.

Work on electrical systems or operating materials may only be performed by a qualified electrician, in accordance with electrical regulations.

Defects, such as damaged cables, cable connections, etc. must be immediately rectified by an authorized specialist.

2. Safety



The yellow power supply cable is electrically live even when the main switch is turned off.

2.4.8 Particular danger zones

When the grinding belt moves to working position, there is a hazard of pinching in the rear area of the machine. Suitable personal protective equipment must be worn.

2.4.9 Servicing (maintenance, repair) and fault rectification

Maintenance work is to be carried out on schedule by trained personnel. Inform operating personnel before beginning repair work. Designate a supervisor responsible for this.

For all service work, the grinding machine is to be disconnected from the current supply and secured against accidental restart. Remove power plug. Secure repair area as necessary.

After completing maintenance work and rectifying any faults, install all safety devices and verify that they are fully functional.

2.4.10 Structural alterations to the grinding machine

Do not make any changes, additions or conversions to the grinding machine without the approval of the manufacturer. This also applies to the installation and setup of safety devices.

Any conversion work requires the written permission from KNECHT Maschinenbau GmbH.

Immediately replace machine parts that are not in perfect condition.

Use only original replacement and wear parts. If externally purchased parts are used, it is not guaranteed that they have been designed and manufactured to meet the requirements in terms of stress and safety.

2.4.11 Cleaning the grinding machine

Properly handle any cleaning agents and materials used and dispose of them in an environmentally-friendly manner.

Dispose of the wear parts and replacement parts in a safe and environmentally-friendly manner.

2. Safety

2.4.12 Lubricants/oils and greases

When using oils and greases, follow the safety regulations applicable to the product. Comply with the special regulations for the food areas.

2.4.13 Relocation of the grinding machine

Disconnect the grinding machine from any external power supply, even in the event of a minor change of location. Before restarting the grinding machine, connect it properly to the power supply.

For loading work, use only lifting equipment and load-bearing devices with sufficient lifting capacity. Appoint a qualified instructor for the lifting operation.

No persons other than those designated for this work may be present in the loading and installation area.

Only lift the grinding machine properly with lifting gear as specified in the operating instructions. Only use a suitable transport vehicle with sufficient load-bearing capacity. Secure the load reliably. Use suitable attachment points.

When restarting the machine, proceed only in accordance with the operating instructions.

3. Description

3.1 Intended Use

The B 500 automatic grinding and polishing machine grinds, deburs and polishes flat machine cutting knives.

3.2 Technical specifications

Height	_____	approx. 1800 mm
Width	_____	approx. 1500 mm
Depth	_____	approx. 1500 mm
Weight	_____	500 kg
Power supply*	_____	3x 400 V
Mains frequency*	_____	50 Hz
Power output*	_____	6.5 kW
Power consumption*	_____	10.5 A
Back-up fuse*	_____	16 A
Control voltage	_____	24 V DC
Compressed air supply according ISO 8573-1:2010 [1:4:2]	_____	6.5 bar (50 l/min)
Measured A-evaluated emission sound pressure level at workstation LpA**	_____	72 dB (A)
Wet grinding belt	_____	2200 x 60 mm
Finned brushes	_____	d.200 x 50 mm

*) This information may change depending on the electrical power supply.

***) Dual number noise emission information according to EN ISO 4871. Noise emission value according to EN ISO 11202 (measurement uncertainty KpA. 3 dB(A)). A K 24 cutter knife RR335 by KNECHT Maschinenbau GmbH was ground.

3. Description

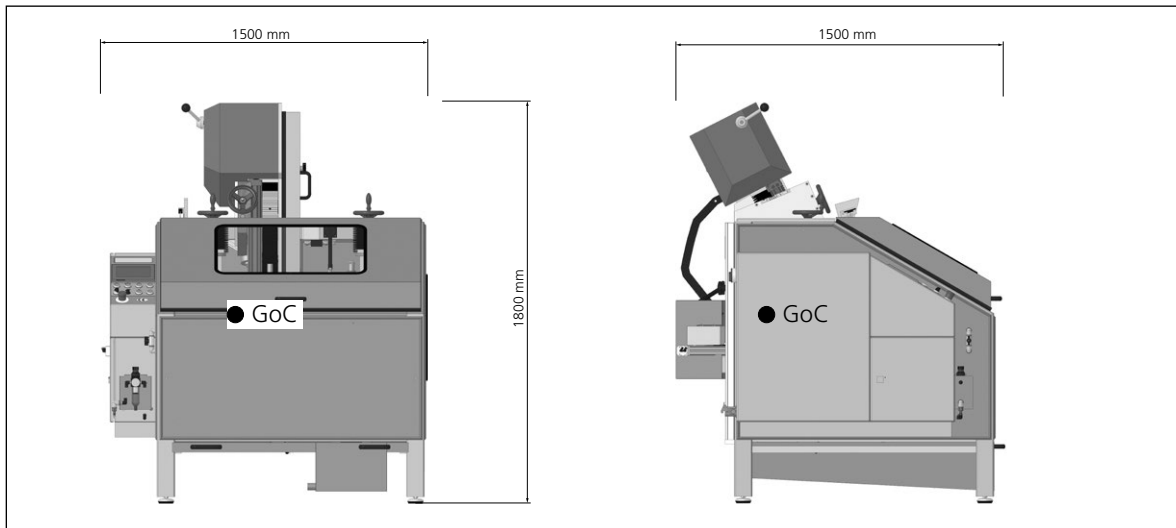

Figure 3-1 Dimensions in mm

3.3 Functional description

The grinding and polishing machine can be used to automatically sharpen, deburr and polish linear and convex flat cutter knives in knife size of maximum 700 x 550 mm.

The knife is fastened onto a copy grinding plate and is moved along the wet grinding belt or the finned brushes in movements that follow the shape of the knife.

Grinding angles between 5° and 35° can be steplessly adjusted on the grinding unit.

In case of emergency, the grinding and polishing machine can immediately be stopped by pressing the "Emergency Stop" button.

3. Description

3.4 Description of the assemblies



Figure 3-2 General view of the grinding machine

- 1 Belt protecting hood
- 2 Belt release lever
- 3 Hand wheel for height adjustment of "deburring unit"
- 4 Rear doors of polishing units (concealed)
- 5 Control panel
- 6 Switch cabinet
- 7 Pneumatic cabinet
- 8 Hand wheel for height adjustment of "polishing unit "
- 9 Protective hood
- 10 Water tray
- 11 Adjustable machine feet

3. Description

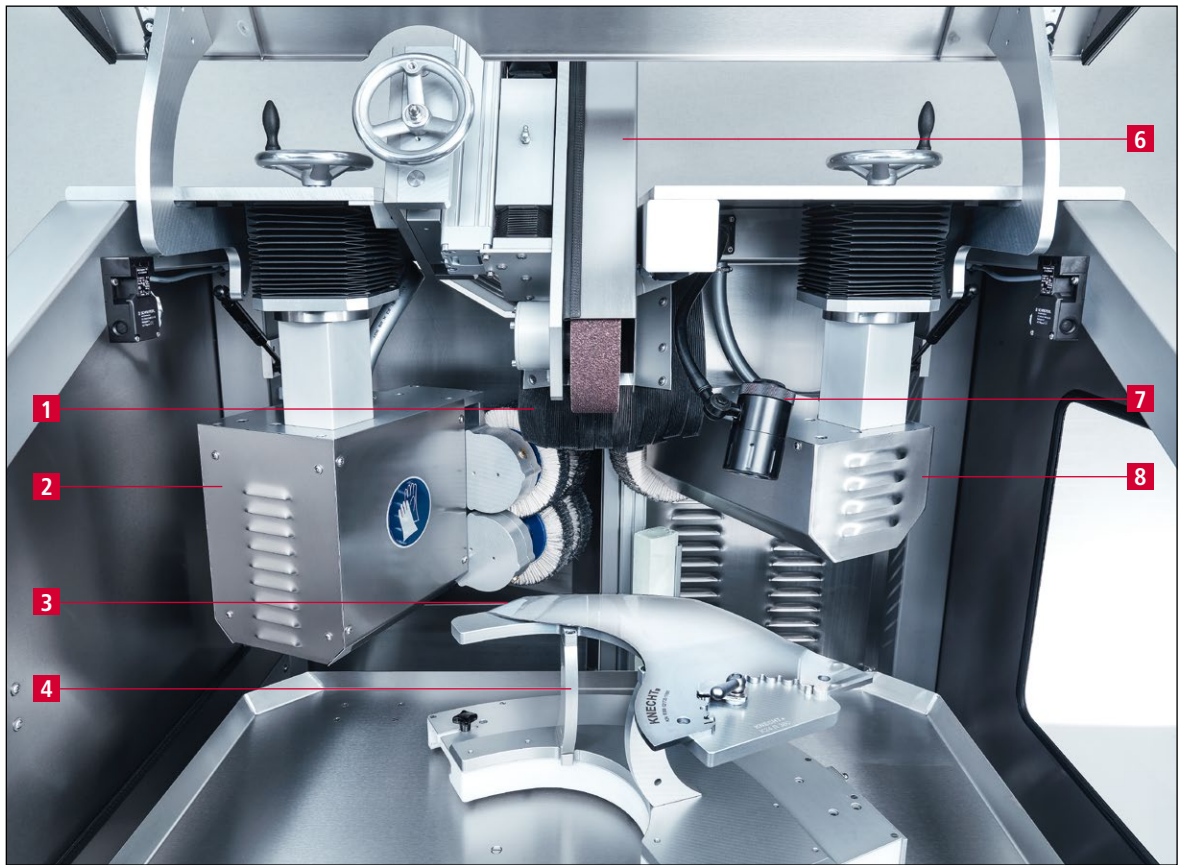

Figure 3-3 Interior view

- 1 Splash guard
- 2 Deburring unit for knife blade
- 3 Knife
- 4 SP 112 Copy grinding plate
- 5 Guard plate
- 6 Grinding unit
- 7 Work lamp
- 8 Polishing unit for backside of knife

3. Description

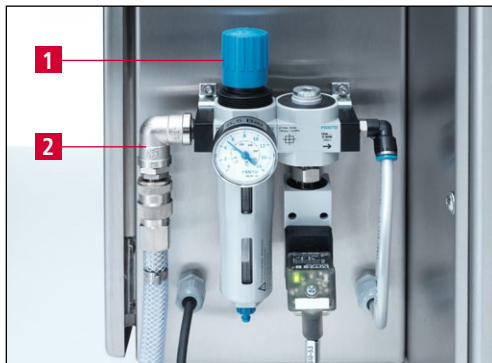

Figure 3-4 Pneumatic system

- 1 Control knob for pressure regulation
- 2 Compressed air connection (6.5 bar)

3.4.1 Switching the grinding machine on/off

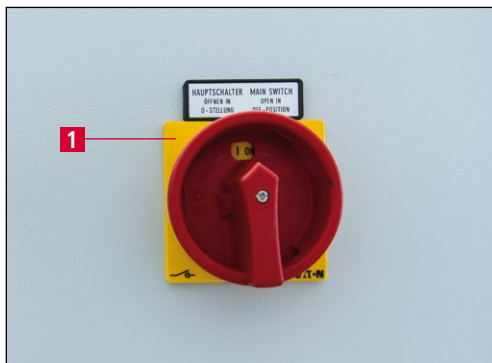

Figure 3-5 Main switch

The main switch (3-5/1) is disposed on the rear of the switch cabinet.

Turning the main switch from “0” to “I” switches on the grinding machine.

Turning the main switch from “I” to “0” switches off the grinding machine.

3.4.2 Control panel

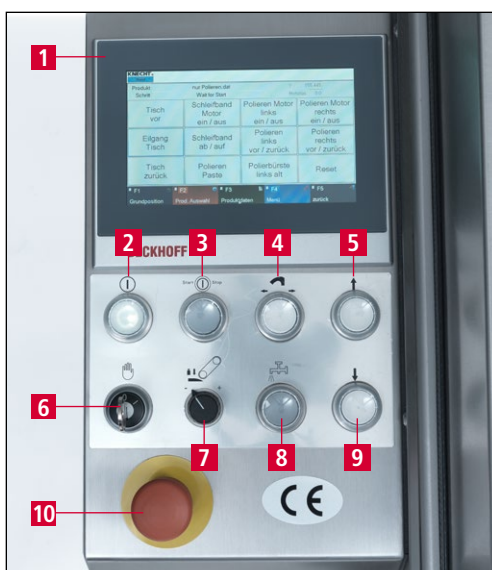

Figure 3-6 Control panel

- 1 Display screen
- 2 “Control On” button: Activates the controls (button starts flashing)
- 3 “Start/Stop” button: Starts/stops the grinding program
- 4 “Change copy grinding plate” button
- 5 “Table forward” button: For moving the table forward
- 6 “Setting Mode” key switch: Position “1” for setting mode
- 7 “Wet grinding belt grinding pressure” selector switch
- 8 “Coolant On/Off” button: Switches the coolant pump on/off
- 9 “Table back” button: For moving the table backward
- 10 “Emergency Stop” button

3. Description

3.4.3 Structure of the user interface (main screen)

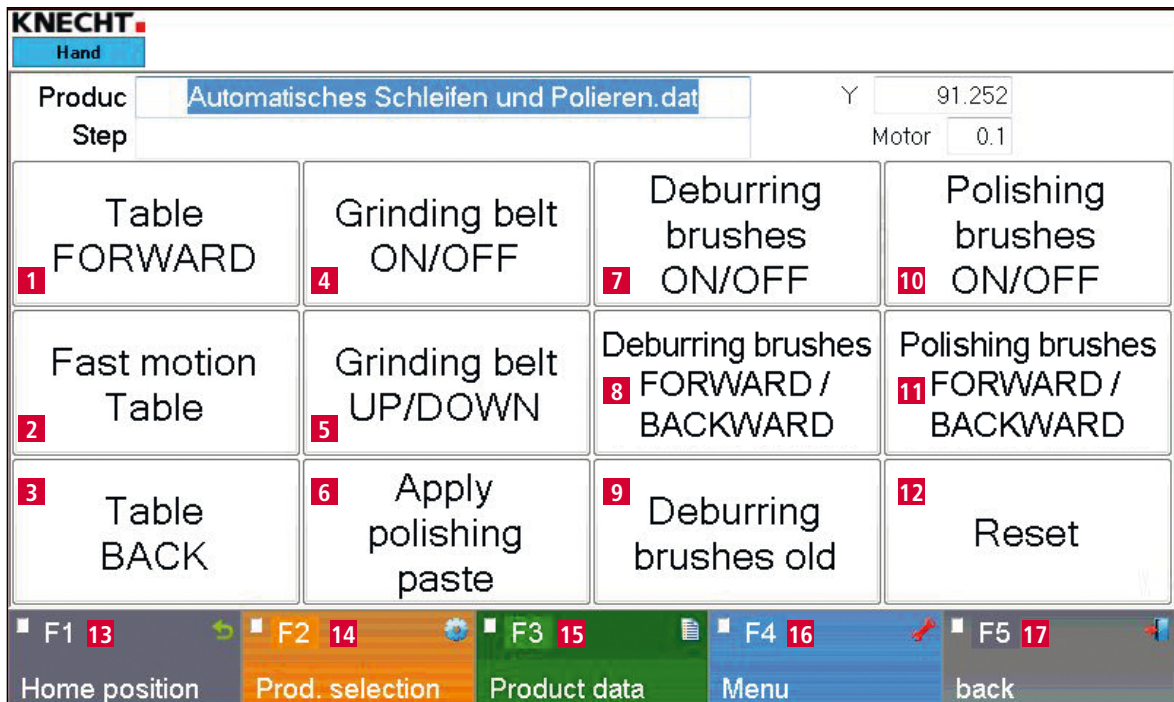

Figure 3-7 Main screen

- 1 **"Table forward"**: For moving the table forward
- 2 **"Fast motion Table"**: Rapid traverse for table forward/backward
- 3 **"Table back"**: For moving the table backward
- 4 **"Grinding belt ON/OFF"**: Switches the wet grinding belt on/off
- 5 **"Grinding belt UP/DOWN"**: For raising/lowering the wet grinding belt
- 6 **"Apply polishing paste"**: Pulse for applying the polishing paste on the finned brushes (in addition to the automatic cycle)
- 7 **"Deburring brushes ON/OFF"**: Switching the deburring unit on/off
- 8 **"Deburring brushes FORWARD/BACKWARD"**: For moving the deburring unit forward/backward
- 9 **"Deburring brushes old"**: Press the touch panel button if brushes are worn out. Slide automatically moves 10 mm further.
- 10 **"Polishing brush ON/OFF"**: For switching the right polishing unit on/off
- 11 **"Polishing brush FORWARD/BACKWARD"**: For moving the polishing unit forward/backward
- 12 **"Reset"**: For deleting temporary fault messages
- 13 **"F1 Home position"**: Moves the table to home position
- 14 **"F2 Prod. selection"**: For selecting the product files
- 15 **"F3 Product data"**: For changing the product data parameters
- 16 **"F4 Menu"**: For managing the settings and language of the user interface
- 17 **"F5 Back"**: For going back to the previous screen

3. Description

ATTENTION

Fast motion highlighted in green: Unit traverses continuously without interruption.

Fast motion highlighted in gray: Unit traverses a predefined distance.

3. Description

3.4.4 Coolant Pump

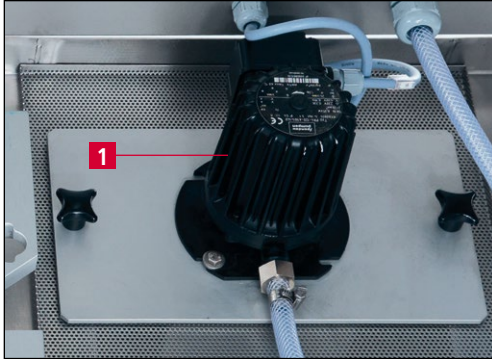

Figure 3-8 Coolant pump

The grinding machine has a coolant pump (3-8/1) with monitoring function.

The coolant pump becomes visible when the right door on the rear side of the machine is opened.

The coolant container sunk in the water tray must be filled with water up to 3 cm below the rim (approx. 15 liters). A coolant additive is not required.



Figure 3-9 Flow gage

The grinding machine has a flow gage (3-9/1) which automatically interrupts the program flow if there is no coolant flow.

The flow gage is in the machine interior and must be cleaned regularly.

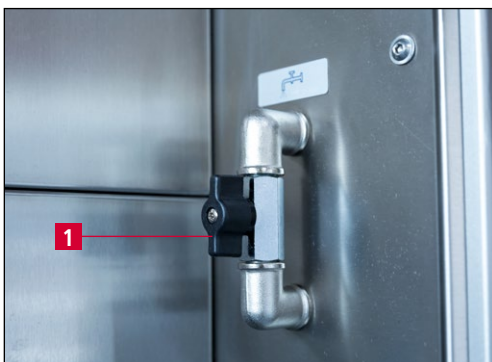

Figure 3-10 Coolant tap

The coolant volume is regulated using the coolant tap (3-10/1).

NOTICE

Turning down the tap too far interrupts the program flow.

3. Description

3.4.5 Protective Hood



Figure 3-11 Protective hood

The protective hood (3-11/1) is not locked during the grinding process. If it or one of the rear doors is opened, the program flow is aborted.

The copy grinding plate can be changed when the protective hood is open.

3.4.6 SP 112 Copy grinding plate



Figure 3-12 SP 112 copy clamping holder

The knives are clamped onto a copy grinding plate (3-12/1) for machining.

A matching copy grinding plate is needed for each knife shape and size. Knives may only be ground using SP 112 copy grinding plates.

The knife change takes less than one minute.

Copy grinding plates for new knife types are available on request from KNECHT Maschinenbau GmbH.

3.4.7 Grinding Unit

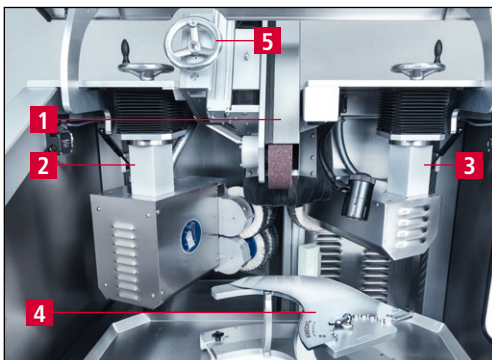

Figure 3-13 Grinding unit

The wet grinding belt (3-13/1) is in idle position above the polishing units (3-13/2 and 3-13/3).

It is lowered onto the knife (3-13/4) for grinding. The grinding angle is adjusted using the hand wheel (3-13/5).

3. Description

3.4.8 Polishing units with polishing paste

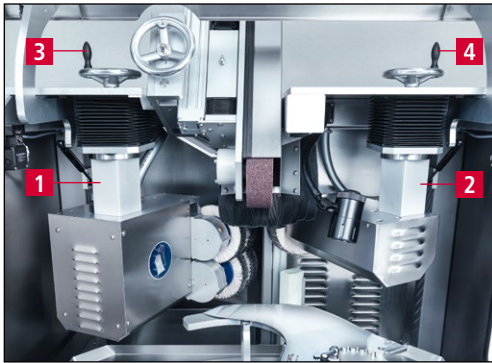

Figure 3-14 Grinding compartment

The grinding machine is equipped with two polishing units ((3-14/1) and (3-14/2)) for polishing the knives.

The deburring unit (3-14/1) swivels forward and deburrs the cutting edge.

The polishing unit (3-14/2) swivels forward to polish the back of the knife.

The position of the polishing units relative to the knives is adjusted with the help of the hand wheels ((3-14/3) and (3-14/4)).

The polishing paste is applied automatically in each case via a pneumatic cylinder.

4. Transport



For transporting the machine, the locally applicable safety and accident prevention regulations must be observed.

Only transport the machine in upright position (with the machine feet facing downwards).

ATTENTION

There are parts jutting out on the underside of the machine which could be easily damaged. Pull out the water tray (3-2/10) before transporting. Drain the water before doing that.

4.1 Transport Aids

For transporting and for setting up the grinding machine, only use adequately dimensioned transport aids, e.g. truck, forklift or hydraulic lift truck.

When using a forklift or a lift truck, move the fork under the grinding machine.

Bear in mind the center of gravity of the machine. The center of gravity (CoG) is shown in figure 3-1.

4.2 Transport damage

If damage is detected after unloading, during acceptance of the delivery, immediately inform KNECHT Maschinenbau GmbH and the forwarding agent. If necessary, an independent expert must be called in immediately.

Remove packaging and fastening straps. Dispose of packaging in an environmentally friendly manner.

4.3 Transport to another installation site

For transport to another installation site, ensure that the space requirements are fulfilled (see Chapter 3.2).

A permitted electrical connection, pneumatic connection and network connection must be available at the new installation site. The grinding machine must stand firmly and securely.

The machine feet must be adjusted so that there is a slight downward slope towards the back.

4. Transport



Installations on the electrical and pneumatic system may only be performed by an authorized specialist.

Observe the locally applicable safety and accident prevention regulations.

5. Installation

5.1 Selection of qualified personnel



It is advisable to have trained KNECHT personnel perform the installation work on the grinding machine.

We assume no liability for damage caused by improper installation.

5.2 Installation site

When determining the installation site, bear in mind the space requirement for installation, maintenance and repair work on the grinding machine (see Chapter 3.2).

5.3 Supply connections

The grinding machine is provided ready to connect with the corresponding connection cable.

The power supply must be installed on site by a qualified electrician.

The compressed air supply and the network connection must be installed on site by a qualified technician.



Confirm that the machine is correctly connected to the current supply.

If connected incorrectly, escaping compressed air and swirling parts can cause injury.

The local safety and accident prevention regulations for compressed air must be observed.

Check that the power supply is connected correctly.

5.4 Settings

The various components and the electrics are adjusted by KNECHT Maschinenbau GmbH before delivery.

ATTENTION

Unauthorized changes to set values are not permitted and may damage the grinding machine.

5. Installation

ATTENTION

Control parameters may only be changed by accordingly qualified personnel. This person must be familiar with the machine functions and the meaning of the parameters. Otherwise, damage to the machine is likely to occur.

5.5 Initial commissioning of the grinding machine

Place the grinding machine at the installation site on a level base.

Level out floor unevenness by adjusting the machine feet (3-2/11) with a flat wrench (SW 17 mm) taking care to ensure that there is a slight downward slope towards the back.

Have an authorized electrician on site install the voltage supply.

Completely install and check the safety devices before commissioning.



CAUTION

Have all the safety devices checked for proper function by trained personnel before commissioning.

Have the compressed air supply installed on site by a qualified expert.



CAUTION

Confirm that the machine is correctly connected to the compressed air supply.

If the machine is connected incorrectly, escaping compressed air and hurtled parts can lead to injuries.

Observing the local safety and accident prevention regulations for compressed air is required.

6. Commissioning



All work on the machine may only be performed by authorized personnel.

The locally applicable safety and accident prevention regulations must be observed.



Figure 6-1 Water tray

Fill the water tray (6-1/1) with water.

Connect the power plug to the power socket provided on site (3x 400 V, 16 A).

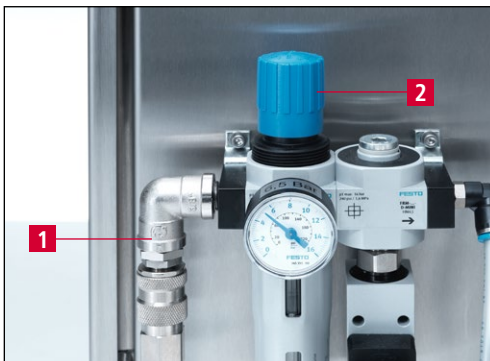

Figure 6-2 Compressed air port

Plug in the compressed air hose at the compressed air port (6-2/1).

Turn the control knob (6-2/2) to adjust the pressure to 6.5 bar.

Close the belt protective hood (3-2/1), rear doors (3-2/4) and protective hood (3-2/9).



Figure 6-3 Control panel

Set the main switch (3-5/1) to "I". Wait for the controls to initialize.

Switch on the control unit with the "Control On" button (6-3/1).

6. Commissioning



Figure 6-4 Checking the direction of rotation

Turn the "Setting Mode" key switch (6-3/2) to position "1".

Press the "Change copy grinding plate" button (6-3/3) and check the direction of rotation of the chain pinion (6-4/1).

The chain pinion must rotate in clockwise direction.

7. Operation

7.1 General principles of grinding technology

If a blade has become blunt, material must be removed from its surface to restore it to its original sharpness.

For that, the knife in question is ground to produce its cutting edge. If, in the process, a burr appears on the blade, then the grinding process was successful and can be concluded. Now, before the final sharpness is achieved, the burr must be removed in a further step. This is done with a finned brush.

As it is not only the sharp cutting edges but also the long service lives that define a blade, the cutting angle is another important indicator of a blade's performance. The smaller the cutting edge angle, the higher the theoretical service life. In practice, however, the cutting edge breaks off and is therefore no longer sharp when the cutting edge angle is too small.

The cutting edge angles must therefore lie between 15° and 35°. If the cutting edge angles are less than 15°, the blade becomes so unstable that it breaks at the slightest resistance. If the cutting edge angle is greater than 35°, the blade is extremely stable, but service life will not be as long.

One more criterion for judging the properties of a cutting edge is the cutting edge profile.

There are three different ground profiles:



Tapered grinding



Convex grinding



Concave grinding

Convex ground profiles can mostly be found on cutter blades and hand knives. Tapered and concave ground profiles are predominantly found on circular knives and blades.

In general: Adhering to the profiles and the cutting edge angles specified by the manufacturer is required

NOTICE

If tapered grinds or concave grinds are to be applied, the grinding machine must be equipped with a harder contact disk.

7. Operation

7.2 Changing the profile

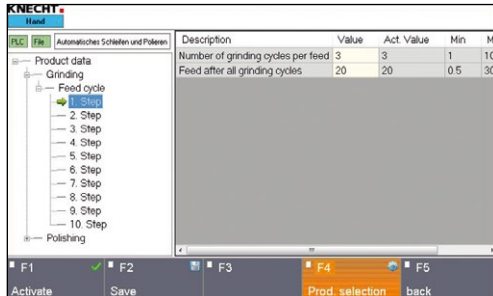

Figure 7-1 "Feed cycles" product data

By default, the grinding machine produces a profile for boiled sausage knives.

If a flatter profile is to be ground, the grinding cycle counter must be incremented after the 2nd feed.

The more often a knife profile is ground, the flatter will be the knife.

If a short profile is to be ground, the number of knife feeds must be reduced.

ATTENTION

Control parameters may only be changed by accordingly qualified personnel. This person must be familiar with the machine functions and the meaning of the parameters. Otherwise, damage to the machine is likely to occur.

7. Operation

7.3 Grinding the cutter knives

7.3.1 Switching on the grinding machine

Set the main switch (see figure 3-5/1) to "I". Wait for the controls to initialize. The main screen appears.

Press the "Control On" button (3-6/2). The control unit is now activated.

Turn the "Setting Mode" key switch (3-6/6) to position "1".

7.3.2 Mounting the copy grinding plate



Figure 7-2 Mounting the copy grinding plate

Push the copy grinding plate (7-2/1) as far as it will go on the ball bearings of the guide carriage (7-2/2) while pressing against the limit stop with the right hand.

Press and hold the "Change copy grinding plate" button (3-6/4) until the copy grinding plate has moved over the limit switch (7-2/3).

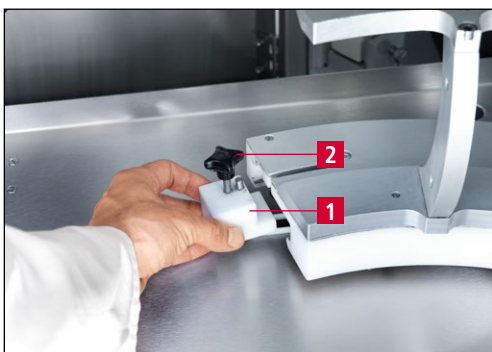

Figure 7-3 Mounting the limit switch cam

With the pin in front, push the limit switch cam (7-3/1) under the copy grinding plate and tighten the star knob (7-3/2).

7. Operation

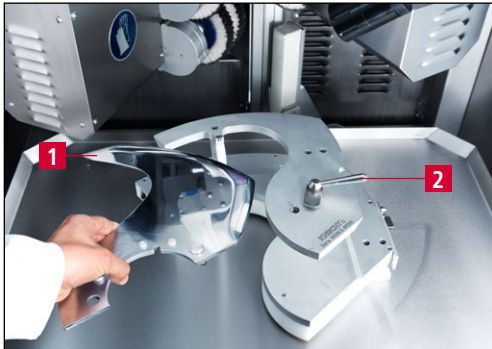

Figure 7-4 Clamping the knife

Place the knife (7-4/1) on the holder of the copy grinding plate and rotate the grinder (7-4/2) on the knife.



This can result in serious cut injuries.

Wear protective gloves.

ATTENTION

Before clamping the knife, check whether the copy grinding plate matches the knife (compare labeling of the copy grinding plate with labeling of the knife). Use of a copy grinding plate that does not match the knife can lead to damage to the knife and the copy grinding plate.

NOTICE

There is a matching copy grinding plate for each cutter knife type. To prepare the matching grinding plate, KNECHT Maschinenbau GmbH needs a knife drawing or a new knife. If possible, specify the cutter type, knife radius and knife type.

7. Operation

7.3.3 Adjusting the grinding angle

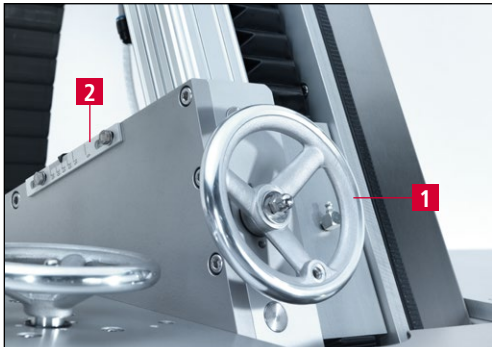

Figure 7-5 Adjusting the grinding angle

Adjusting the grinding angle with the hand wheel (7-5/1).

The grinding angle can be read off the scale (7-5/2).

7.3.4 Aligning the grinding unit

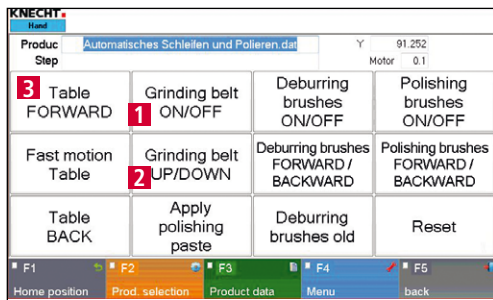

Figure 7-6 Main screen

Turn the "Setting Mode" key switch (3-6/6) to position "1".

Move wet grinding belt to working position by pressing the "Grinding belt UP/DOWN" button (7-6/2) on the touch panel.

Open the coolant tap (3-10/1) roughly halfway.

Press the "Table forward" button (7-6/3) on the touch panel until wet grinding belt and knife are almost touching each other.

Press the "Change copy grinding plate" button (3-6/4). Check the direction of travel of the copy grinding plate and press the button again as necessary to make the copy grinding plate move in the desired direction. Hold the button in depressed position until the copy grinding plate stops moving. The wet grinding belt is now at the knife tip.

7. Operation

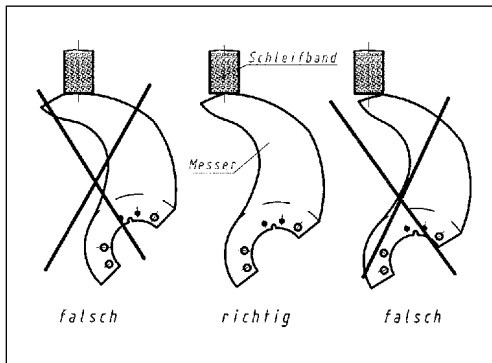

Figure 7-7 Adjusting the path of the copy grinding plate

The grinding unit has been aligned properly if the path of the copy grinding plate is sufficient for grinding the entire blade length.

If the blade end does not reach the grinding belt center (see figure 7-7), the limit switch cam (7-3/1) must be re-adjusted.

7. Operation

7.3.5 Aligning the deburring unit

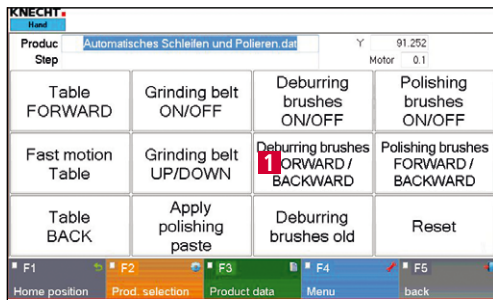

Figure 7-8 Main screen

As the upper and lower brushes of the deburring unit wear off with different levels of abrasion over time, the position of the deburring unit must be realigned at regular intervals.

Swivel the deburring unit towards the knife with the “Deburring brushes FORWARD/BACKWARD” (7-8/1) button in the manual functions on the touch panel.

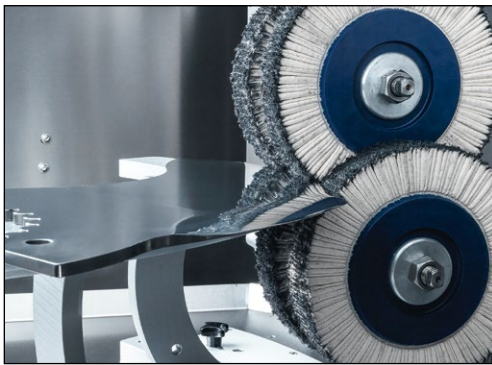

Figure 7-9 Aligning the deburring unit

Use the hand wheel to adjust the height (3-2/3) of the “Deburring unit” (3-3/2) so that the knife edge is at the point of intersection of the finned brushes.

ATTENTION

The height of the deburring unit must be adjusted so that the point of intersection of the finned brushes lies on the knife edge.

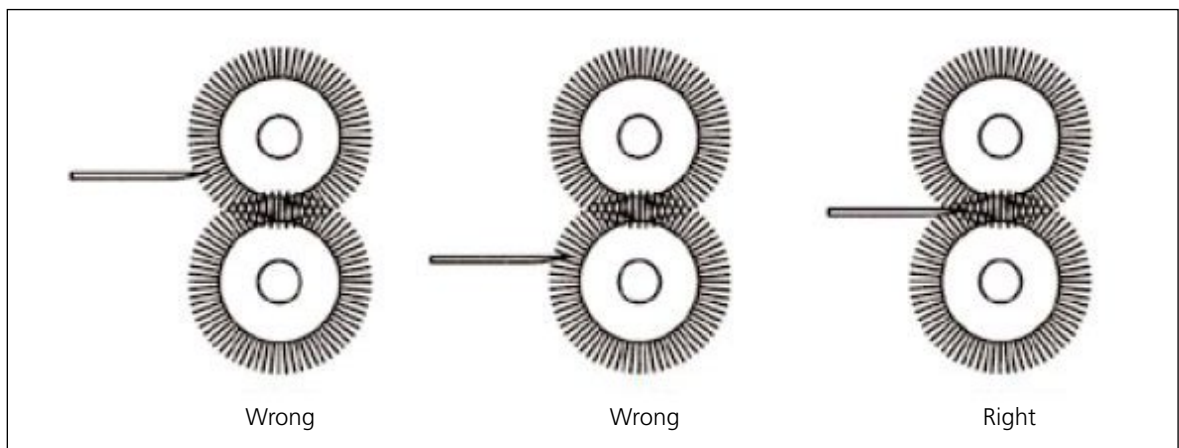

Figure 7-10 Aligning the deburring unit

7. Operation

7.3.6 Aligning the polishing unit

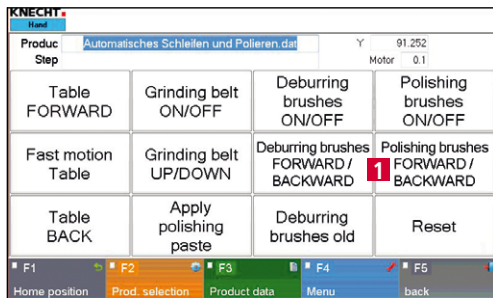

Figure 7-11 Main screen

Swivel the polishing unit towards the knife with the “Polishing brushes FORWARD/BACKWARD” (7-1 1/1) button in the manual functions on the touch panel.



Figure 7-12 Aligning the polishing unit

Use the hand wheel to adjust the height (3-2/8) of the “Polishing Unit” (3-3/8) so that the finned brush touches the knife.

7.3.7 Starting the grinding process



Figure 7-13 Control panel

Open the coolant tap (3-10/1) roughly halfway. Close the protective hood.

Set the “Setting Mode” key switch (7-13/2) to “0” and press the “Start/Stop” button (7-13/1). The grinding program starts.

The program flow can be aborted at any time by pressing the “Start/Stop” button (7-13/1). The copy grinding plate will move back to home position.

7. Operation

7.4 Changing the copy grinding plate



CAUTION

Never change the copy grinding plate with knives clamped.

There is a risk of crushing and pinching at the drive pinion.

This can result in serious injuries.

Only press the "Change copy grinding plate" button (3-6/4) with the copy grinding plate mounted.

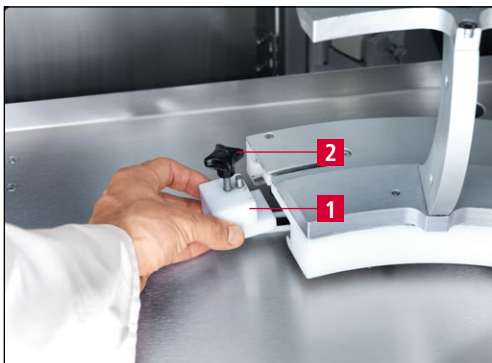

Figure 7-14 Changing the copy grinding plate

Loosen the star knob (7-14/2).

Take out the limit switch cam (7-14/1).



Figure 7-15 Control panel

Set the "Setting Mode" key switch (7-15/1) to "1" and press the "Change copy grinding plate" button (7-15/2). Check the direction of travel of the copy grinding plate and press the button again as necessary to make the copy grinding plate move in the desired direction. Hold the button in depressed position until the copy grinding plate stops moving.

Then detach the copy grinding plate from the guide carriage by hand without twisting it and keep it in a safe place.

7. Operation

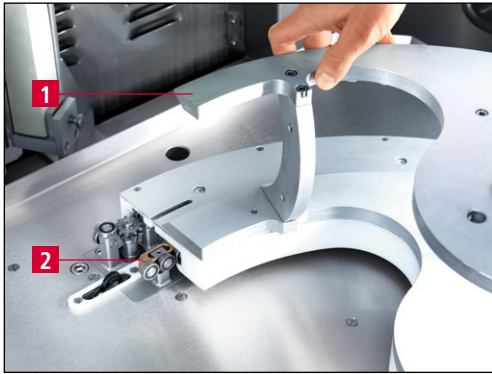

Figure 7-16 Pushing the copy grinding plate onto the guide carriage

Push the copy grinding plate (7-16/1) as far as it will go onto the ball bearings of the guide carriage (7-16/2) while pressing against the limit stop with the right hand.

Press and hold the "Change copy grinding plate" button (7-15/2) until the copy grinding plate has moved 2-3 cm.

With the pin in front, push the limit switch cam (7-14/1) under the copy grinding plate and tighten the star knob (7-14/2).

NOTICE

If the copy grinding plate has not been inserted properly, push it in by hand.

7. Operation

7.5 Changing the wet grinding belt



CAUTION

For all work on the grinding and polishing machine, the locally applicable safety and accident prevention regulations as well as instructions in the "Safety" and "Important Notes" section of the operating instructions must be observed.

ATTENTION

Only original grinding belts may be used.

Incorrect grinding belts can lead to overheated blades that can cause knife breaks.



Figure 7-17 Changing the wet grinding belt

Pull the belt protective hood (7-17/1) upward and remove.

Turn the belt release lever (7-17/3); unload and remove the wet grinding belt (7-17/4).

Load the new wet grinding belt taking care that the direction of rotation is correct (the direction of rotation of the motor is counter-clockwise). There is a direction arrow on the grinding unit (7-17/2) to check the direction of rotation.



Figure 7-18 Adjusting the wet grinding belt

If the wet grinding belt is not running exactly on the contact disk, it can be aligned with the belt control knob (7-18/1).

Turning the belt control knob in counter-clockwise direction makes the wet grinding belt run to the left. Turning in clockwise direction makes the belt run to the right.

7. Operation

7.6 Changing the finned brush of the polishing unit

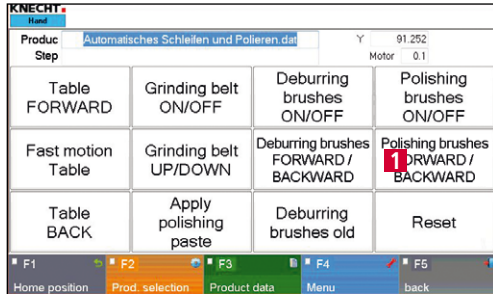

Figure 7-19 Main screen

Close the protective hood.

Press "Polishing brushes FORWARD/BACKWARD" button (7-19/1) on the touch panel.

The polishing unit swivels forward.

ATTENTION

Set the "Setting Mode" key switch (3-6/6) to position "1" so that the polishing unit remains in front when the protective hood opens.



Figure 7-20 Changing the finned brush of the polishing unit

Open the protective hood and insert the bar (7-20/1) in the hole in the clamping flange behind the finned brush.

Insert the tap wrench (7-20/2) in the holes of the clamping flange and unscrew in clockwise direction.

Exchange the finned brush and screw back the clamping flange in counter-clockwise direction.

ATTENTION

Only original abrasives from KNECHT Maschinenbau GmbH are permitted to be used.

KNECHT Maschinenbau GmbH assumes no responsibility for the use of non-original abrasives.

7. Operation

7.7 Changing the finned brushes of the deburring unit

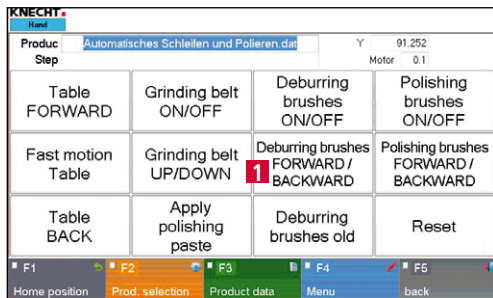

Figure 7-21 Main screen

ATTENTION



Figure 7-22 Changing the finned brushes of the deburring unit

ATTENTION

Close the protective hood.

Press "Deburring brushes FORWARD/BACKWARD" button (7-21/1) on the touch panel.

The deburring unit on the left swivels forward.

Set the "Setting Mode" key switch (3-6/6) to position "1" so that the deburring unit remains in front when the protective hood opens.

Open the protective hood and loosen the upper nut (7-22/1) in counter-clockwise direction using the SW 22 mm flat wrench. Loosen the lower nut (7-22/2) in clockwise direction.

Remove the finned brushes and flange and mount the new finned brushes in reverse sequence. Screw the nuts back again.

Only original abrasives from KNECHT Maschinenbau GmbH are permitted to be used.

KNECHT Maschinenbau GmbH assumes no responsibility for the use of non-original abrasives.

7. Operation

7.8 Changing the polishing pastes

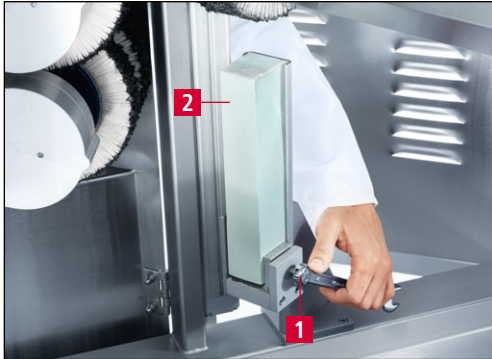

Figure 7-23 Changing the right polishing paste

Open the rear doors and unscrew the clamping claw with an SW17 combination wrench (7-23/1). Take out the polishing paste (7-23/2).

Insert new polishing paste. Screw the clamping claw back again.

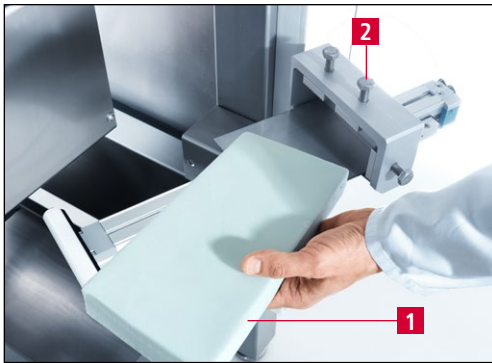

Figure 7-24 Changing the left polishing paste

Proceed in the same way for changing the polishing paste on the left (7-24/1).

Then screw the clamping claw (7-24/2) back again.

ATTENTION

A new polishing paste must initially be supported with a plate underneath. This prevents the paste from breaking off. The supporting paste must be removed as soon as approximately half of the polishing paste has been used up.

Tighten the clamping claw only lightly until the pyramidal tips are pressed all the way into the paste.

Use only original polishing pastes as the knives will otherwise not be sharpened properly.

8. Control system

8.1 Main Screen

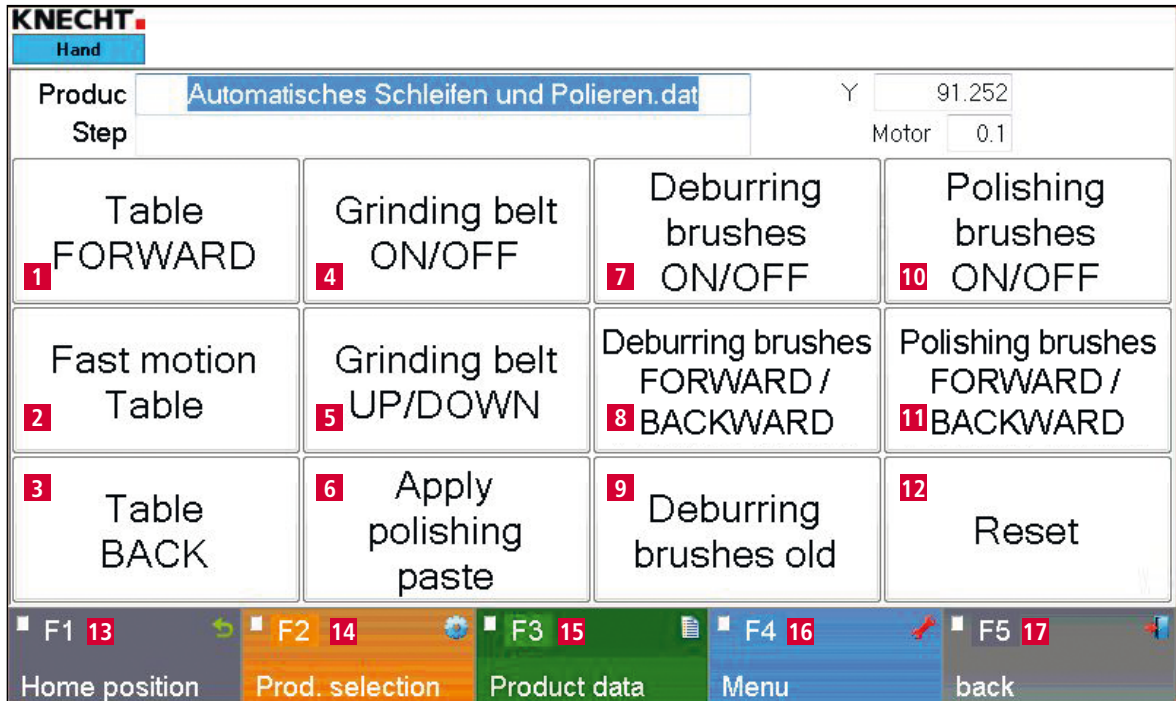

Figure 8-1 Main screen

- 1 **"Table forward"**: For moving the table forward
- 2 **"Fast motion, table"**: Rapid traverse for table forward/backward
- 3 **"Table back"**: For moving the table backward
- 4 **"Grinding belt ON/OFF"**: Switches the wet grinding belt on/off
- 5 **"Grinding belt UP/DOWN"**: For raising/lowering the wet grinding belt
- 6 **"Apply polishing paste"**: Pulse for applying the polishing paste on the finned brushes (in addition to the automatic cycle)
- 7 **"Deburring brushes ON/OFF"**: For switching the deburring unit on/off
- 8 **"Deburring brushes FORWARD/BACKWARD"**: For moving the deburring unit forward/backward
- 9 **"Deburring brushes old"**: Press the touch panel button if brushes are worn out. Slide automatically moves 10 mm further.
- 10 **"Polishing brushes ON/OFF"**: Switching the right polishing unit on/off
- 11 **"Polishing brushes FORWARD/BACKWARD"**: Moving the polishing unit forward/backward
- 12 **"Reset"**: For deleting temporary fault messages
- 13 **"F1 Home position"**: Moves the table to home position
- 14 **"F2 Prod. selection"**: For selecting the product files
- 15 **"F3 Product data"**: For changing the product data parameters
- 16 **"F4 Menu"**: For managing the settings and language of the user interface
- 17 **"F5 Back"**: For going back to the last view

8. Control system

ATTENTION

Fast motion highlighted in green: Unit traverses continuously without interruption.

Fast motion highlighted in gray: Unit traverses a predefined distance.

8.2 Activating the product file

A separate product file for each grinding task is stored. This product file must be selected and loaded before grinding in automatic mode.

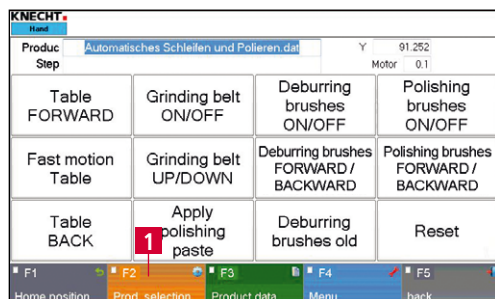

Figure 8-2 Main screen

The procedure is as follows:

Activate the “F2 Prod. Selection” (8-2/1) touch panel button. A new window (8-3) opens.

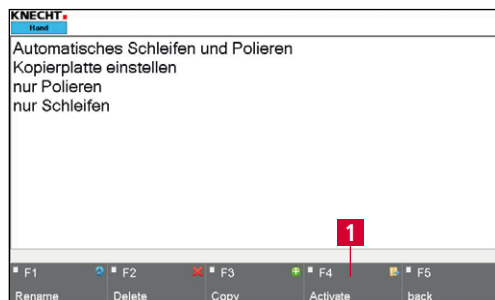

Figure 8-3 Selecting the product file

Select the desired file so that it is highlighted in blue.

Load the product file in the control unit via the “F4 Activate” (8-3/1) touch panel button.

The program automatically switches back to the main screen.

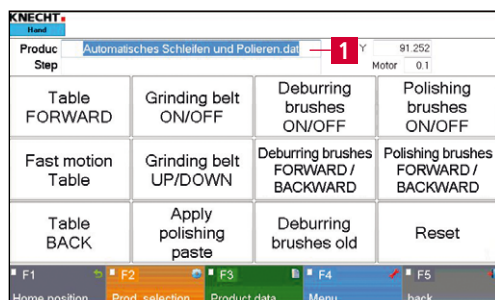

Figure 8-4 Main screen

The new product file appears in the “Product” row (8-4/1). The new parameters are now loaded by the control unit.

8. Control system

8.3 Renaming, creating and deleting the product file

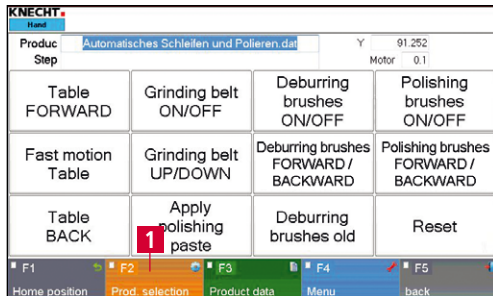

Figure 8-5 Main screen

Product files can be renamed, deleted and new ones created by copying.

The procedure is as follows:

Activate the "F2 Prod. Selection" (8-5/1) touch panel button.

A new window (8-6) opens.

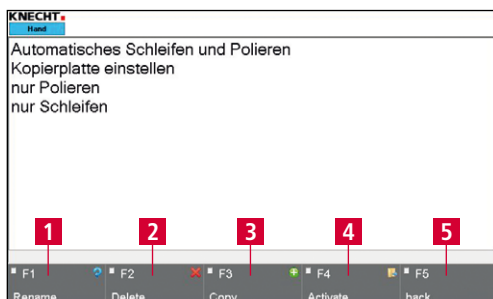

Figure 8-6 Editing the product file

Select the desired file so that it is highlighted in blue.

Select the relevant touch panel button: "F1 Rename" (8-6/1), "F2 Delete" (8-6/2) or "F3 Copy" (8-6/3).

8.3.1 Renaming product file



Figure 8-7 Renaming the product file

On pressing "F1 Rename" (8-6/1), a window as displayed in the figure on the left (8-7) opens.

Edit the file name (8-7/1) using the keyboard and confirm with "OK" (8-7/2).

The window closes. The renamed file appears in the product file directory.

Then activate a product file with "F4 Activate" (8-6/4) or return to the main screen with "F5 Back" (8-6/5).

8. Control system

8.3.2 Creating the product file



Figure 8-8 Creating the product file

On pressing "F3 Copy" (8-6/3), a window as displayed in the figure on the left (8-8) opens.

Edit the file name (8-8/1) using the keyboard and confirm with "OK" (8-8/2).

The window closes. The new file appears in the product file directory.

Continue with Chapter 8.4 to edit the parameters of the product file.

8.3.3 Deleting the product file

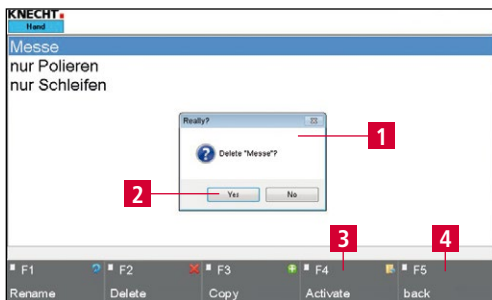

Figure 8-9 Deleting the product file

On pressing "F2 Delete" (8-6/2), a pop-up window (8-9/1) opens.

Confirm with "Yes" (8-9/2); cancel with "No".

The pop-up window closes.

Then activate a product file with "F4 Activate" (8-9/3) or return to the main screen with "F5 Back" (8-9/4).

8. Control system

8.4 Editing the parameters of the product file

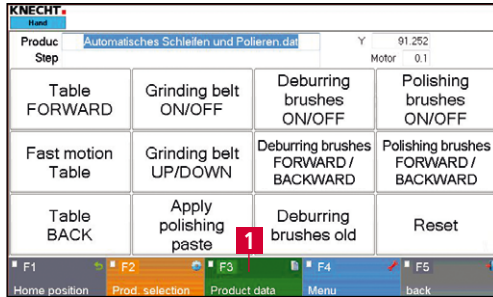

Figure 8-10 Main screen

The parameters of a product file can be changed as follows:

Press the “F3 Product Data” (8-10/1) touch panel button on the main screen.

A new window (8-11) opens.

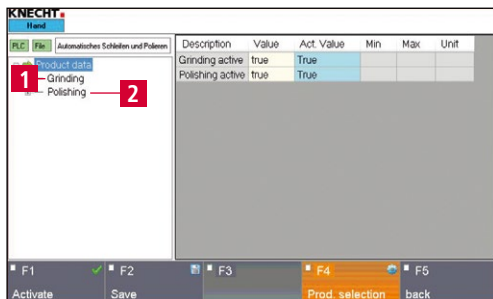

Figure 8-11 Parameter groups

There are two different parameter groups:

“Grinding” (8-11/1): Grinding process data (see Chapter 8.4.1)

“Polishing” (8-11/2): Polishing process data (see Chapter 8.4.3)

The active group is always indicated with a green arrow. To activate a group, press the name. The arrow moves forward and the group is highlighted in blue.

8. Control system

8.4.1 Meaning of "Grinding" parameters

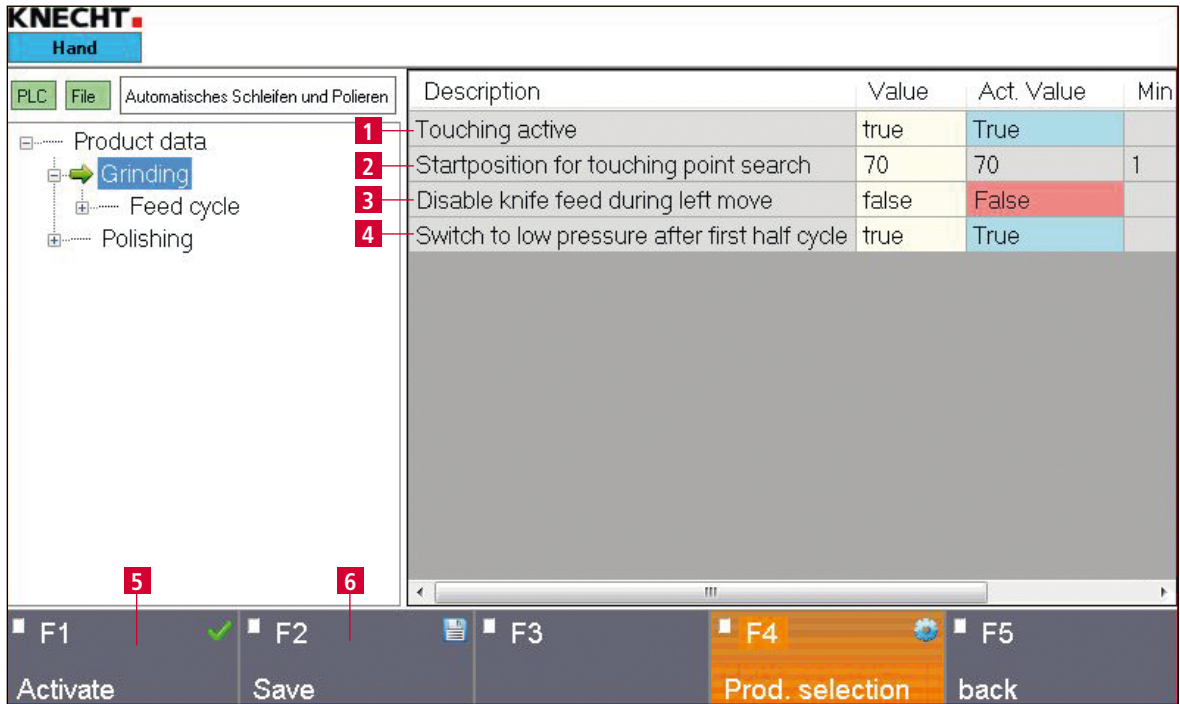

Figure 8-12 "Grinding" parameters

- 1 **Touching active:** true = touching enabled, false = touching disabled
- 2 **Startposition for touching point search:** Path that the knife covers for touching in fast motion before speed is reduced (in mm)
- 3 **Disable knife feed during left move:** true = confirm reset disabled, false = confirm reset enabled
- 4 **Switch to low pressure after first half cycle:** true = Pressure reduction activated, false = Pressure reduction deactivated

To change the parameters, tap on the relevant button highlighted in yellow. Tap on "Numbers" to open the window as shown in (8-13); tap on "Values" to open the window as shown in (8-14).

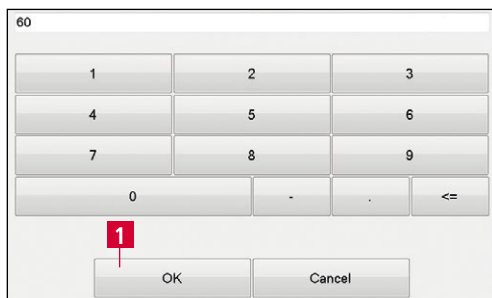

Figure 8-13 Editing the "Numbers" parameter

Select the desired number and confirm with "OK" (8-13/1).

The "Cancel" touch panel button closes the window without accepting the number.

8. Control system

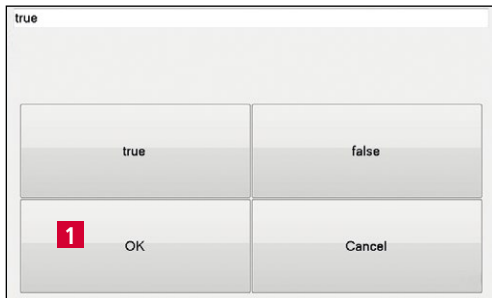

Figure 8-14 Editing the “Values” parameter

In the window for “Values”, select between “true” and “false” and confirm with “OK” (8-14/1).

The “Cancel” touch panel button closes the window without accepting the value.

ATTENTION

Save the changed values with the “F2 Save” (8-12/6) touch panel button.

If a current product file is changed, overwrite via the “F1 Activate” (8-12/5) touch panel button of the control system.

8. Control system

8.4.2 Meaning of "Feed Cycles" parameter

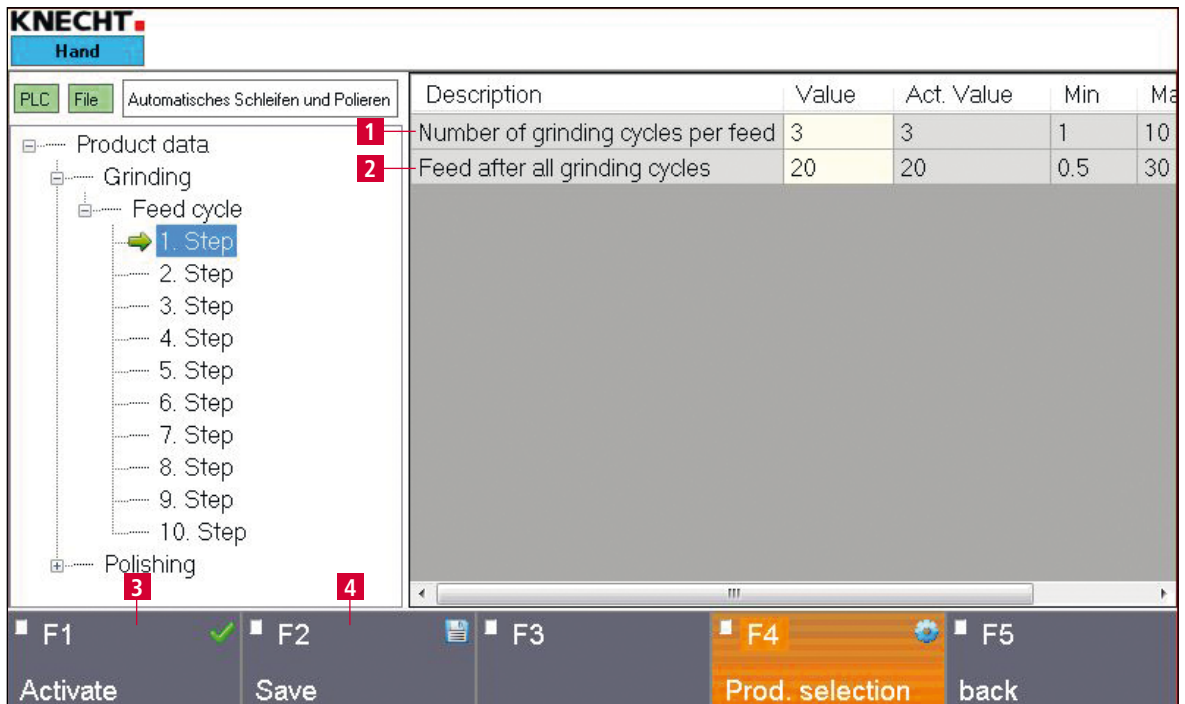

Figure 8-15 "Feed cycles" parameter

- 1 **Number of grinding cycles per feed**: Number of cycles in a particular step; the step is not carried out if the value is "0".
- 2 **Feed after all grinding cycles**: Path that the knife covers to the next step after completing processing of the previous step (in mm)

NOTICE

The above parameters refer to the 2nd-10th step.

To change the parameters, tap on the relevant button highlighted in yellow. A window (8-16) opens when you click "Numbers".

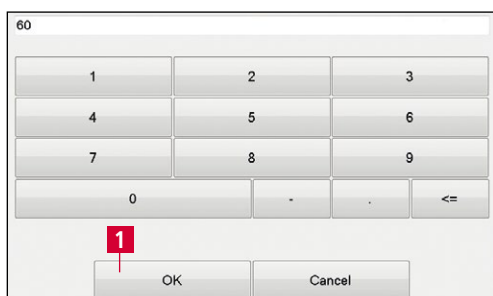

Figure 8-16 Editing the "Numbers" parameter

Select the desired number and confirm with "OK" (8-16/1).

The "Cancel" touch panel button closes the window without accepting the number.

8. Control system

ATTENTION

Save the changed values with the "F2 Save" (8-15/4) touch panel button.

If a current product file is changed, overwrite via the "F1 Activate" (8-15/3) touch panel button of the control system.

8. Control system

8.4.3 Meaning of "Polishing Process" parameters

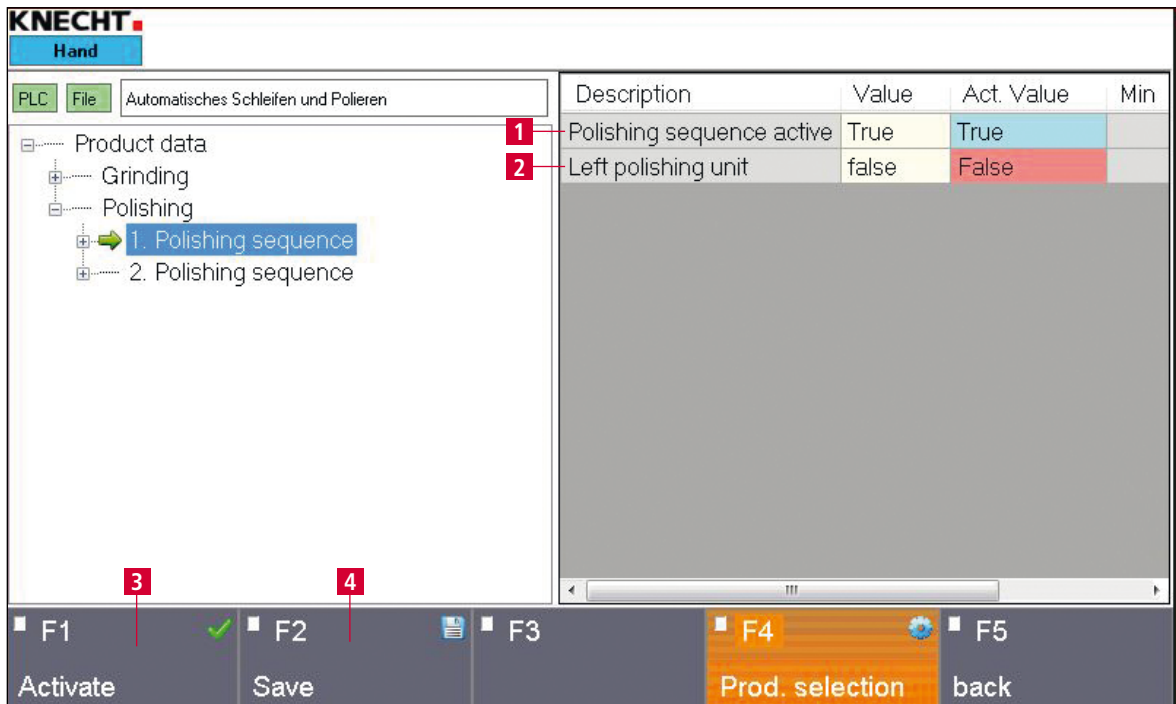

Figure 8-17 "Polishing process" parameter

- 1 **Polishing sequence active:** true = polishing process activated, false = polishing process deactivated
- 2 **Left polishing unit:** true = deburring unit activated, false = right polishing unit activated

NOTICE

The above parameters refer to the 2nd polishing process.

To change the parameters, tap on the relevant button highlighted in yellow. Tap on "Numbers" to open the window as shown in (8-18); tap on "Values" to open the window as shown in (8-19).

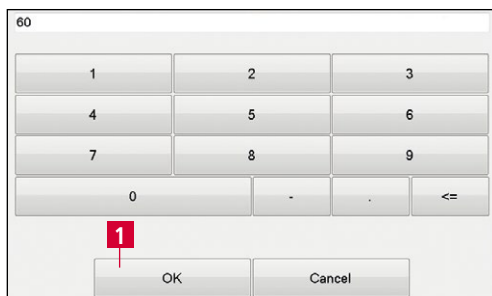

Figure 8-18 Editing the "Numbers" parameter

Select the desired number and confirm with "OK" (8-18/1).

The "Cancel" touch panel button closes the window without accepting the number.

8. Control system

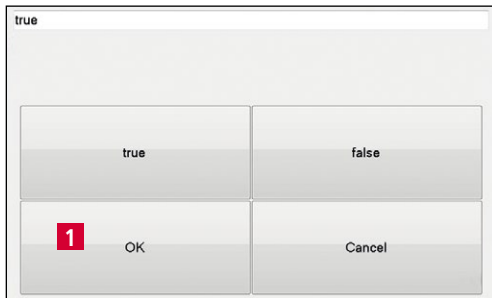

Figure 8-19 Editing the “Values” parameter

ATTENTION

In the window for “Values”, select between “true” and “false” and confirm with “OK” (8-19/1).

The “Cancel” touch panel button closes the window without accepting the value.

Save the changed values with the “F2 Save” (8-17/4) touch panel button.

If a current product file is changed, overwrite via the “F1 Activate” (8-17/3) touch panel button of the control system.

8. Control system

8.5 Settings Data

The settings data are called via the main menu "F4 Menu" (8-1/16) followed by "F2 Settings Data".

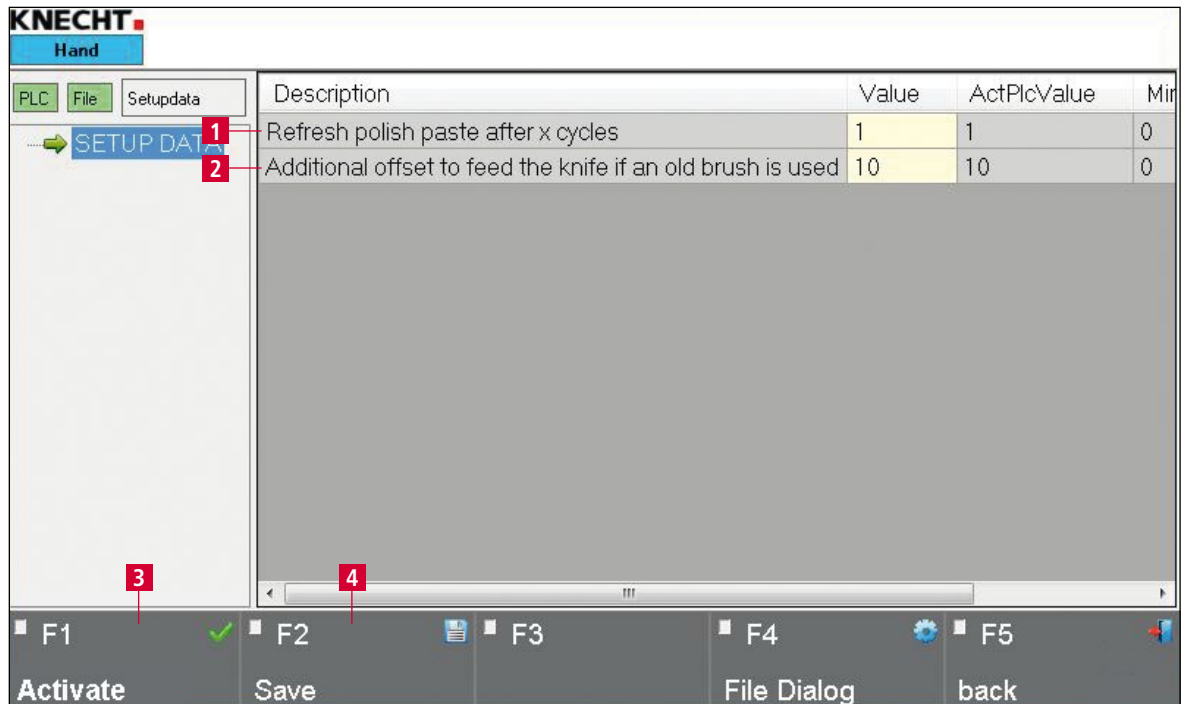

Figure 8-20 Settings data

- Refresh polish paste after x cycles:** Number of grinding cycles before the polishing paste is automatically applied on the finned brushes
- Additional offset to feed the knife if an old brush is used:** On pressing the touch panel button in the main screen (8-1/9), the slide moves forward by the set value so that the left finned brushes can function optimally (in mm)

To change the parameters, tap on the relevant button highlighted in yellow. A window (8-21) opens when you click "Numbers".

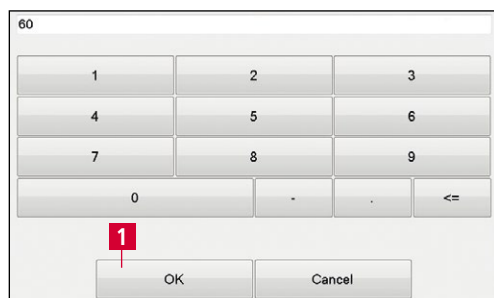

Figure 8-21 Editing the "Numbers" parameter

Select the desired number and confirm with "OK" (8-21/1).

The "Cancel" touch panel button closes the window without accepting the number.

8. Control system

ATTENTION

Save the changed values with the "F2 Save" (8-20/4) touch panel button.

If a current product file is changed, overwrite via the "F1 Activate" (8-20/3) touch panel button of the control system.

8. Control system

8.6 Manual Functions

The manual functions allow you to operate the machine by hand. They are called via the main menu "F4 Menu" (8-1/16) followed by "F3 Manual Functions". Various functions of the machine can be individually activated/deactivated.

ATTENTION

Buttons highlighted in green are enabled.
Buttons highlighted in gray are disabled.

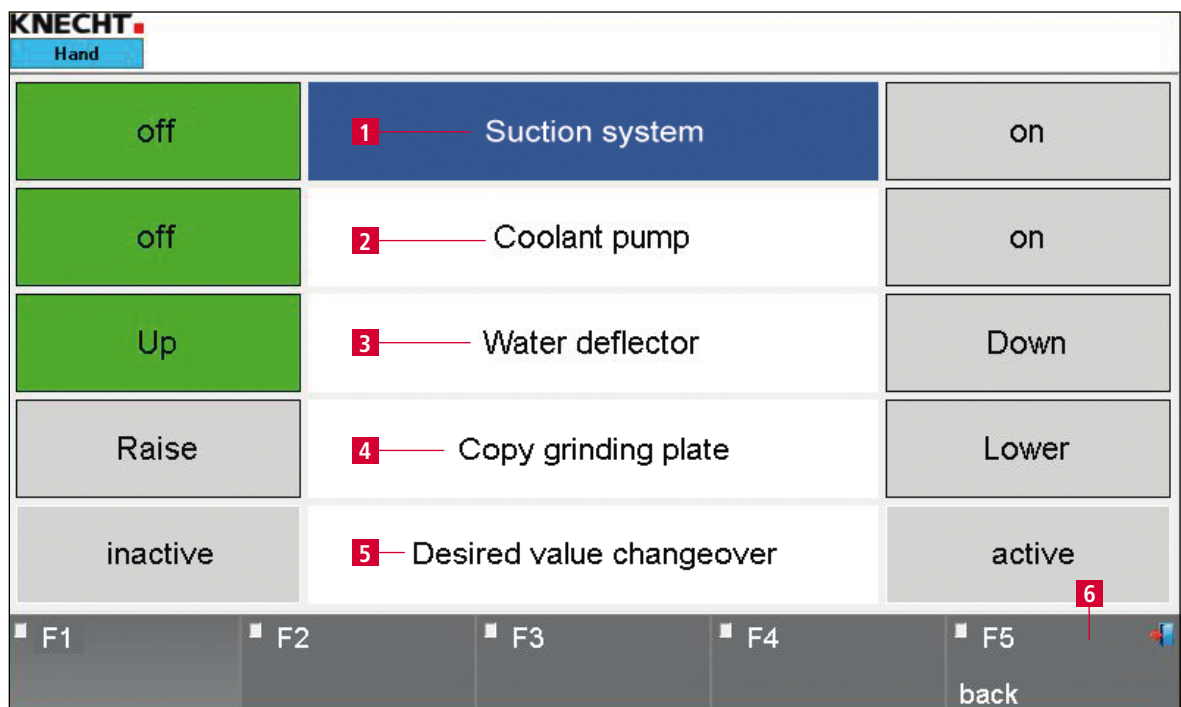

Figure 8-22 Manual functions

- 1 Switch the suction system on/off
- 2 Switch coolant pump on/off
- 3 Water deflector Up/Down
- 4 Copy grinding plate Raise/Lower
- 5 Activate/deactivate setpoint switching
- 6 **F5 back:** Takes you back to the previous screen

8. Control system

8.7 Language

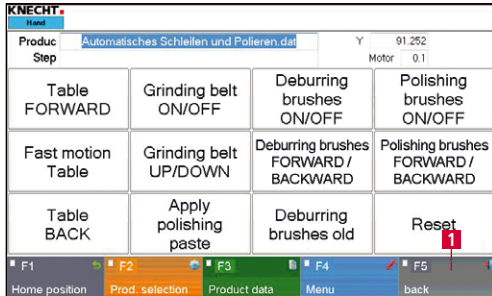

Figure 8-23 Main menu

The user interface language can be changed to the language of the country of use.

Press the touch panel button "F5 Back" (8-23/1) to go back to the start screen.

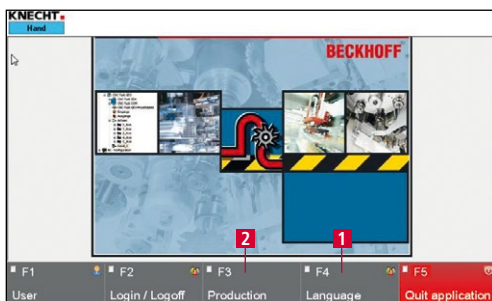

Figure 8-24 Start screen

Press the "F4 Language" (8-24/1) touch panel button.

A new window (8-25) opens.

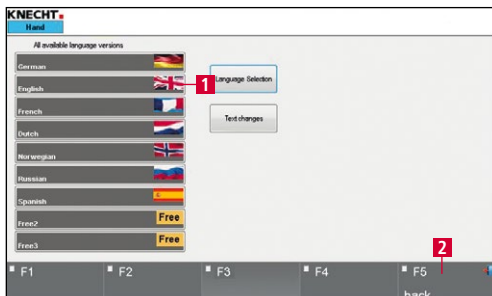

Figure 8-25 Selecting the language

The desired language is selected and automatically activated by pressing the corresponding touch panel button (8-25/1).

Then return to the start screen by pressing the "F5 Back" (8-25/2) touch panel button.

The main screen appears when the "F3 Production" (8-24/2) button is pressed.

8. Control system

8.8 Setting up an internet connection



Figure 8-26 Switch cabinet

The machine has an Ethernet connection. Use the optional, integrated VPN router to create a secure connection between the machine and KNECHT Maschinenbau GmbH. This connection can be enabled or disabled by the operator using the key switch on the control cabinet (8-26/1).

Through this connection, KNECHT service technicians can access the controller and carry out Perform a machine diagnosis, change software settings, and install or edit new grinding programs.

An active Internet connection is required to create the connection.

NOTICE

When commissioning, the VPN router is configured according to the specified IT infrastructure so that the machine communicates exclusively with KNECHT Maschinenbau GmbH via the VPN server. Any communication within the customer network is excluded. The customer network is therefore optimally protected.

In order to establish the Internet connection, plug the supplied Ethernet cable into the on-site network socket (RJ45) and the network port on the control cabinet (8-26/1) of the grinding machine.

9. Care and maintenance

9.1 Lubrication and Maintenance

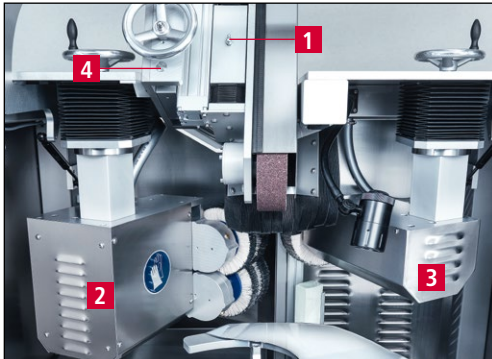

Figure 9-1 Grease fitting

There is one grease fitting each in the front and rear of the guideway housing (9-1/1).

To access the grease fitting of the polishing unit, the cover plate (9-1/2) and the motor hood (9-1/3) must be removed.

One shot of the grease gun must be pressed into each grease fitting every six months.

The guideways and adjusting spindles for angle adjustment (9-1/4) must be greased every six months.

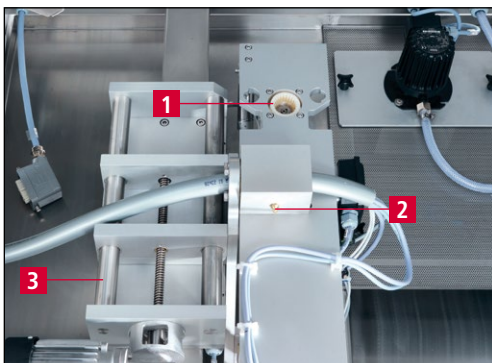

Figure 9-2 Lubricating points

The Bowex coupling (9-2/1), the grease fitting (9-2/2) of the swivel mechanism and the knife feed guideways (9-2/3) must be greased every six months.



Figure 9-3 Flow gage

Remove and clean the flow gage (9-3/1) every six months.

For this purpose, disconnect the connector (9-3/2) and turn the flow gage in counter-clockwise direction by hand. Clean the measuring probe with a clean cloth.

Slightly grease the thread (not the probe) and tighten back again.

Re-assemble in reverse sequence.

9. Care and maintenance

9.1.1 Lubrication schedule and lubricant table

Lubricating activity	Interval	OEST	SHELL	EXXON Mobil
Grease machine parts after cleaning	After each grinding operation	Paraffinum Perliquidum 16L	Shell Risella 917	Marcol 82
Lubricate copy grinding plate paths on the guard plate	Daily	Multi-purpose grease L2	Gadus S2 V 100 2	Mobilith SHC 100
Lubricate thread of star knobs, clamping lever, flow gage and Bowex coupling	Semi-annually	Multi-purpose grease L2	Gadus S2 V 100 2	Mobilith SHC 100
Lubricate parts with grease fittings (see Figure 9-1)	Semi-annually	Multi-purpose grease L2	Gadus S2 V 100 2	Mobilith SHC 100
Lubricate guideways and adjusting spindles	Semi-annually	Multi-purpose grease L2	Gadus S2 V 100 2	Mobilith SHC 100

9. Care and maintenance

9.2 Cleaning

Clean the machine after each grinding process to prevent grinding sludge from drying, hence making it harder to remove.

After cleaning, lightly grease the machine with non-corrosive oil (also refer to lubrication schedule in Chapter 9.1.1).

The coolant must be changed every week.

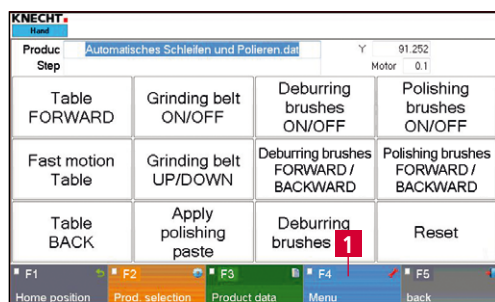

Figure 9-4 Main screen

The copy grinding plate can be lowered for cleaning the machine.

To do that, close the protective hood.

Press the "F4 Menu" (9-4/1) touch panel button on the main screen. A new window (9-5) opens.

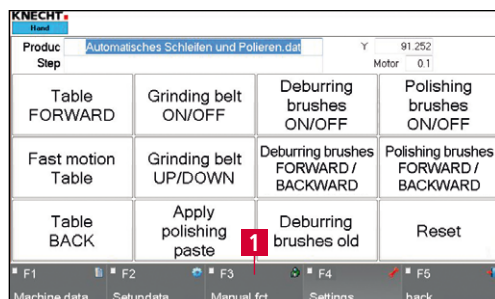

Figure 9-5 Menu

Press the "F3 Manual Function" (9-5/1) touch panel button to call the manual function of the machine.

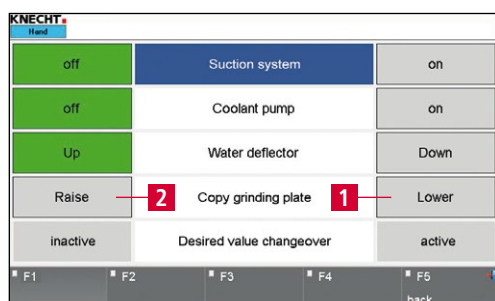

Figure 9-6 Manual functions

Press the "Lower" button (9-6/1) on the touch panel. The copy grinding plate is lowered and the grinding sludge can be removed with water.

To raise the copy grinding plate, press the "Raise" button (9-6/2) on the touch panel.

ATTENTION

Dispose of the coolant in an environmentally friendly way!

9. Care and maintenance

9.2.1 Cleaning of sub-structure



Figure 9-7 Dismantling the guard plate

The guard plate (9-7/1) can be dismantled for cleaning and servicing the sub-structure.

First, open the rear doors (3-2/4) on the backside of the machine and pull out the connector plug underneath the guard plate.

Then turn the Allen screws (9-7/2) all the way to the stop in counter-clockwise direction from the front. To do that, use a SW10 Allen wrench.

The guard plate can now be pulled forward and out of the machine.

Re-assemble the guard plate in reverse sequence.

ATTENTION

Be careful while re-assembling the guard plate as the limit switch and cable could be damaged otherwise.

Finned brushes must not get wet, since they can only absorb polishing paste and can only correctly deburr a knife in dry state.

9. Care and maintenance

9.3 Maintenance plan

Interval	Assembly	Maintenance task
Daily	Polishing paste	Clean the paste feed and ensure that it is moving freely.
		If the left polishing paste has worn to the support plate, immediately remove support plate (see section 7.8).
	Water system	Check the fill level of the water trough.
Weekly	Grinding belt drive	Remove belt protection hood, remove and clean contact disc.
	Polishing unit	Check diameter of the finned brushes. If smaller than 165 mm, install new finned brushes
		Remove the polishing paste from the finned brushes using a cleaning brush. After cleaning, reapply the polishing paste to the brushes (see Figure 8-1/6).
	Base	Clean and lubricate the guides and horizontal spindle.
	Copy grinding plate	Oil the drive chain.
		Check felt pads.
		Check grinder and knife holding fixture.
Monthly	Grinding belt drive	Check rubber profile on belt protection hood for leak tightness.
	Polishing unit	Clear the water drainage hole on the underside of the polishing unit guard.
		Lubricate polishing unit if there is an increased level of noise.
Semi-annually	Grinding belt drive	Re-grease lubrication nipple.
	Base	Re-grease lubrication nipples of swivel block.
	Water system	Remove and clean flow gauge.
	HV 551 Slide plate	Check chain sprocket for wear.
		Check drive shaft for play.
		Check travel rollers of limit switches for wear.
		Check ball bearings of guide carriage for wear.
Annually		Contact service department of KNECHT Maschinenbau GmbH.

10. Disassembly and disposal

10.1 Disassembly

All operating materials must be disposed of correctly.

Secure moving parts against slipping.

The disassembly must be carried out by a qualified specialist company.

10.2 Disposal

At the end of the machine service life, it must be disposed of by a qualified specialist company. In exceptional cases and in agreement with KNECHT Maschinenbau GmbH, the machine can be returned.

Operating materials (e.g. grinding belts, finned brushes, coolant etc.) must also be disposed of correctly.

11. Service, spare parts and accessories

11.1 Postal Address

KNECHT Maschinenbau GmbH
Witschwender Straße 26
88368 Bergatreute
Germany

Phone +49-7527-928-0
Fax +49-7527-928-32

mail@knecht.eu
www.knecht.eu

11.2 Service

Service management:

See postal address

service@knecht.eu

11.3 Wear and spare parts

If you need spare parts, please use the spare parts list provided with the machine. Please place your order as shown below.

Please always include the following information: (Example)

Machine type	(B500)
Machine serial number	(820463500)
Designation of assembly	(4-way paste feed)
Designation of individual part	(Roller)
Item number (position number)	(10)
Drawing number (article number)	(2000127-8848)
Quantity	(1 pc.)

Please feel free to contact us with any questions.

11. Service, spare parts and accessories

11.4 Accessories

11.4.1 Abrasives used

Type	Dimension	Grain	Order number	Remark
Wet grinding belt	2200x60	80	412A-62-0725	
	2200x60	100	412A-63-0726	
	2200x60	120	412A-64-0727	
	2200x60	240	412A-66-0728	
Wet grinding belt, compact grain	2200x60	180	412A-70-0180	Assembled on delivery
Sisal finned brush (right)	d.200x50xd.25		412J-02-8150	Assembled on delivery
Polishing paste (right)	230x60x50		412R-01-0501	Assembled on delivery
Sisal finned brush (left)	d.180x30xd.17		412J-02-0180	Assembled on delivery
Polishing paste (left)	250x40x140		412R-06-0140	Assembled on delivery

ATTENTION

Only original abrasives, wear and spare parts from KNECHT Maschinenbau GmbH are permitted to be used.

KNECHT Maschinenbau GmbH assumes no responsibility for the use of non-original parts.

If you require wet-grinding belts, finned brushes, polishing pastes or other accessories, please contact our sales staff, dealers, or KNECHT Maschinenbau GmbH directly.

Thank you for choosing KNECHT!

12. Appendix

12.1 EU Declaration of Conformity

in accordance with the EU Directive 2006/42/EU

- Machinery 2006/42/EU
- Electromagnetic Compatibility 2014/30/EU

We hereby declare that the machine designated as follows, due to its construction and design, as well as the version we placed on the market, complies with the relevant fundamental safety and health requirements of the applicable EU Directive.

In case of a modification of the machine not agreed with us, this declaration loses its validity.

Designation of the machine: Automatic Grinding and Polishing Machine
Type designation: B 500

Machine number: from no. 1070468500

**Applicable harmonized standards,
in particular:** DIN EN ISO 12100
DIN EN ISO 13857
DIN EN ISO 16089
DIN EN 61000-3-2
DIN EN 61000-3-3
DIN EN 55014-1
DIN EN 349

Responsible for the documentation: Peter Heine (Dipl. Ing. Mechanical Engineering)
Phone +49-7527-928-15
p.heine@knecht.eu

Manufacturer: KNECHT Maschinenbau GmbH
Witschwender Straße 26
88368 Bergatreute
Germany

A complete technical documentation is available. The operating instructions document for the machine is available in its original version and in the native language of the user.

The validity of the declaration expires in the event of changes to the legal requirements.

Bergatreute, November 2, 2023

KNECHT Maschinenbau GmbH

Markus Knecht
CEO

KNECHT Maschinenbau GmbH

Witschwender Straße 26 · 88368 Bergatreute · Germany · T +49-7527-928-0 · F +49-7527-928-32
mail@knecht.eu · www.knecht.eu